

Tractor Safety

background information & activity book



Tractor Safety Educational Packet

This educational packet is designed to teach tractor safety to elementary through middle school students.

The material developed and disseminated by Farm Safety For Just Kids was peer reviewed and is intended for general information and educational purposes only. It should not be relied upon as medical or legal advice. If legal, medical, or other expert assistance is required, the services of the appropriate professional should be sought.

Refer to the Farm Safety For Just Kids web site at www.FarmSafetyForJustKids.org for additional information.

Copyright © 2015 Farm Safety For Just Kids

Reviewers:

Dr. Paul Ayers
Professor
University of Tennessee

George Cook
Farm Safety Specialist
University of Vermont Extension

LaMar Grafft
Associate Director
North Carolina Agromedicine Institute

Funding provided by:



Table of Contents

EDUCATIONAL INFORMATION

A Leader's Guide to Teaching Farm Safety	Page 4
Introduction	Page 5
Tractor Hazards	Page 6
Mechanical Hazards	Page 10
Safety Features	Page 11
Equipment/Implements	Page 15
Education/Training	Page 17
Evaluation	Page 18
Resource Listing	Page 20

LESSON PLANS

Tractor Safety Attitude Continuum	Page 20
Working Youth	Page 21
Slow Moving Vehicle (SMV) Emblems	Page 25
Seatbelt Safety	Page 27
Drive Head Over Wheels	Page 29
Tractor Hazards	Page 30
Tractor Stability	Page 35

PUZZLES

Crossword Puzzles	Page 49
Sudoku Puzzles	Page 44
Tractor Bingo	Page 46
Square Eights	Page 47
Safe Operation	Page 48
Window Boxes	Page 50
From Start to Finish and Everything in Between	Page 51
Tractor Detective	Page 52
Coloring Pages	Page 53
Tractor Safety Secret Code	Page 57
Mechanical Hazards Match-Up	Page 58
Answer Keys	Page 59

Educational Information

A Leader's Guide to Teaching Farm Safety	Page 4
Introduction	Page 5
Tractor Hazards	
Overturns and Runovers	Page 6
Hydraulic Systems	Page 6
Extra Riders	Page 7
Mechanical Hazards	Page 8
Falls	Page 8
Tractor Roadway Use	Page 9
Safety Features	
ROPS	Page 11
SMV Emblems	Page 11
Lighting	Page 12
Fire Extinguishers	Page 12
Pre-Operational Checks	Page 12
Tractor Maintenance	Page 13
Tractor Stability	Page 14
Equipment/Implements	
Front end loaders	Page 15
Towing implements	Page 15
PTOs	Page 15
Education/Training	Page 17
Evaluation	Page 18
Resource Listing	Page 20

A Leader's Guide to Teaching Tractor Safety

Several topics or main themes arise when teaching children and youth how to stay safe while in the vicinity of tractors on the farm. Listed below is a chart of several suggested tractor-related topics to consider when planning tractor safety lessons. It serves as a general guide, but is not intended to be strictly followed as each child is unique in his/her own developmental stage and experience.

	Under 5 years old Rules and Concepts	5 to 10 years old Rules and Concepts	11 to 13 years old Rules and Concepts	Working Youth
Extra Riders on Tractors	Never ride on a tractor	Understand the physical dangers of being an extra rider	Understand the health hazards to themselves as extra riders, as well as for the tractor operator	Both riding on a tractor and allowing passengers is risky. Both practices should be discouraged
Falling from Tractors	Do not climb on tractors	Understand the consequences of falling off a tractor	Understand the repercussions of falling from a tractor	Take precautions such as cleaning steps, and wearing non-slip shoes
Tractor Proximity	Always stay away from tractors	Notify the tractor driver of your presence when nearby. The driver may not be able to see you	Notify the tractor driver of your presence when nearby. The driver may not be able to see you	Be alert when driving tractors for the sake of those close by
Tractor Safety Features	Information is inappropriate for this age group	Identify moving tractor parts and shields that protect people	Understand tractor features that impact safety	Understand and use tractor safety features to protect yourself
Tractor Implements	Stay away from all working and non-working tractor implements	Stay away from working tractor implements	Understand why implements can be hazardous to both the operator and any bystander	Hitch implements with caution and follow safe procedures when operating a tractor

The main objective of educating children, especially young ones, about tractor safety is to teach them to stay away from tractors. Tractors hold potential hazards not only to the driver, but to those in close proximity. As children grow and develop, they begin to understand abstract concepts. Rules for very young children are black and white, while rules for older children, who are beginning to understand more are based on comprehension and complexity of the hazard. This allows them to begin to connect the concept of hazardous mechanisms, resulting hazards, and possible injuries. If children understand these hazards, they are more likely to follow the rules that are intended to keep them safe. The lesson plans included in this educational packet have a suggested age for each activity. Many of the activities can be adapted to other age groups by simplifying or adding more details.

Background

Tractors play a major role on the farm. Since tractors took over the work load of horses and mules in the first part of the 20th century, they have made a major impact on modern agricultural production. Tractors are the most common piece of farm equipment. They transport equipment and material, pull implements, and provide power for other equipment.

Tractors are intended to assist operators in doing work on the farm. They can be large and very powerful. Their size and strength can be the source of harm when not used properly. Tractors are used on rough, uneven ground and can make sharp turns. If this is done at high speeds, or by an untrained operator, it can cause injury.

Agriculture, mining, and construction are ranked as the top three most hazardous industries in the United States. Tractors are involved in approximately

32% of the agricultural related injuries, with 44% of U.S. tractor-associated deaths related to overturns specifically.

The leading source of fatal injuries to children on the farm is machinery which includes tractors. Tractor overturns, runovers, power take-off (PTO) entanglements, and collisions with non-farm vehicles on public roads are the leading causes of farm related death and serious injuries in the United States. Each year, more than 250 farmers, their family members and employees die as a result of tractor-related incidents. Half of these deaths occur when a tractor overturns and crushes the operator. The University of Kentucky estimates that 4.46 non-fatal injuries from overturns occur for every fatality.

This manual is intended to be used as a reference guide when conducting programs about tractor safety. It can be used when instructing young children about the dangers that tractors pose to them as bystanders or extra riders. This information is also useful when youth first begin to learn about driving a tractor.

This manual is not intended to replace safety training or certification courses; instead it helps children too young for certification training courses to understand the dangers and ways to prevent injuries.

The puzzle section complements certification classes and other instruction while this educational information helps the instructor to understand the dangers present in each situation. Read the educational information before conducting lesson plans, playing interactive games, giving a PowerPoint presentation, or distributing work sheets. Use the questions within each section to engage students in discussion and increase learning and retention.

There are guidelines that help parents and employers determine the appropriate time for youth to begin operating a tractor. The North American Guidelines for Children's Agricultural Tasks (NAGCAT) were developed to help adults match up a child's unique physical and mental abilities with the tasks involved in completing different agricultural jobs.

Check with your local extension office, Vo-Ag instructor, state agricultural university, and implement dealers for additional tractor safety resources. A listing of specific web based resources is included at the end of this section.

Tractor Hazards

OVERTURNS AND RUNOVERS

Tractor overturns are major causes of injuries and deaths to tractor operators. When this occurs, people are seriously impacted physically and they also experience property damage, medical bills, loss of work time, and reduced productivity. On the farm, tractors cause more deaths (36%) than any other item.

For example, in Ontario, Canada, 244 people died as a result of tractor-related incidents between 1980 and 1994. This accounted for almost 48% of the total fatalities for that period. The vast majority (about half) of these deaths were fatalities caused by tractor overturns to the side or the rear.

Side overturns usually take place when the tractor is being used on sloped surfaces. As the slope increases, the chance of a side overturn is greater. The center of gravity is altered toward the downward slope. The chance of a side overturn also increases if obstacles and rough surfaces or pot holes are being driven on. Side mounted implements also increase the chance of side overturns. Keep side mounted implements on the uphill side of the tractor to increase stability. Avoid turning on a slope, if possible, or turn downhill, if you must. When driving close to a ditch or embankment stay as far away from the edge as possible. The weight of the tractor can cause the ground to give way.

Rear overturns sometimes take place when implements are improperly hitched behind the tractor. If a chain or rope is hitched too high on the tractor when pulling something out of the ground, the tractor can be pulled over backwards. This can also happen if there is not enough weight on the front of the tractor. Weight can be added to the front to prevent the tractor from tipping backward. If a rear overturn takes place, there is only 1.5 seconds to react and not enough time to escape from the weight of the tractor.

Overturns can also take place when driving up a steep slope. If brakes are applied to decrease the speed of the tractor, the tractor can pivot on the back axle causing the front end to rise. The steeper the slope, the greater the danger. When driving across a hill where the stability of the tractor is uncertain, turn the tractor toward the downward slope. A sudden uphill turn is more likely to cause tipping.

Another cause of overturns is driving out of mud or ice. If the back tires are stuck, the front end may raise up causing the tractor to tip backwards. Back the tractor out when it is stuck.

Runovers can occur when the operator/passenger falls from the tractor, or another person is runover by the machine's tires. Many youth are killed each year in this manner. Always wear a seatbelt in the presence of a ROPS and make sure the area is clear of others before starting the tractor to prevent a runover.

Tractor overturn/runover prevention tips:

- ▶ When given the option, drive tractors on the flattest possible land.
- ▶ Keep side mounted implements on the uphill side of the tractor.
- ▶ Avoid turning on slopes. Turn downhill, versus uphill, when turning is a necessity.
- ▶ Stay away from the edge of ditches and steep slopes.
- ▶ Attach hitches to the drawbar.
- ▶ Make sure tires are not frozen to the ground or stuck in mud before moving the tractor.
- ▶ Do not allow passengers on tractors.
- ▶ Check surroundings for individuals close by.

Question & Answer

Q: If you have a younger brother or sister, how can you help protect them from being involved in a tractor runover situation?

A: Children, especially young ones, are often not seen by tractor drivers due to their small size. Older siblings can watch smaller children when on the farmstead preventing them from approaching a tractor.

HYDRAULIC SYSTEMS

Hydraulics can lift heavy hay bales; raise steel implements; or lift machines off the ground. How can a small device produce so much power?

Hydraulic systems use pressure built up by fluids within a small space. Any liquid can be pressurized but some work better than others. Complete Activity 5 on page 34 to demonstrate that even water can be pressurized.

Oil is used as the liquid with tractor hydraulic systems. As the hydraulic fluid moves through a closed system of hoses, the fluid meets resistance, pressure increases, and heat up as the friction builds. Pressure within the hydraulic system can exceed 2,000 pounds per square inch (psi). This pressure is used to lift items such as loader buckets and implements.

The tremendous pressure is where the danger lies. With this much pressure, pin-hole leaks can develop in the hoses. The hydraulic fluid (oil) is forced in very small hoses with small openings. If a hose breaks or cracks, the oil will release with strong force. This force is powerful enough to damage human tissue by injecting oil under the skin causing a medical emergency.

The following precautions should be taken when around hydraulic systems:

- ▶ Wear safety glasses and sturdy gloves when checking hydraulic systems.
- ▶ Shut off the engine before servicing.
- ▶ Lower the implement and support or block the implement with something other than the hydraulic cylinder itself.
- ▶ Check for leaks in the hydraulic lines using a piece of cardboard. Even a small amount of hydraulic fluid that escapes can be injected into flesh. Seek immediate medical attention if this occurs.
- ▶ Release the block or transport locks carefully. If pressure is lost, an implement can fall without warning.
- ▶ If the hydraulic system should fail, the machinery can fall on a unsuspecting worker or bystander. Stay clear and do not stand under machinery.

Adults should be responsible for checking and operating hydraulic systems. Youth need to understand the dangers and reasons for staying away from hydraulic systems.

Question & Answer

Q: What are the main hazards of being around tractor hydraulics?

A: Released pressure from a faulty hose or poor connection is the major hazard of tractor hydraulics. Heat produced by the pressure is another hazard associated with hydraulics. These hazards may not be observable at first glance.

Q: As a youth, what is your role in preventing injuries related to hydraulic systems?

A: Understanding the mechanics of a hydraulic system should be sufficient to warn youth that they should stay away from hydraulic hoses. Do not touch any hose, but tell an adult if you notice that a hose is deteriorating.

EXTRA RIDERS

Allowing extra riders is one of the leading causes of fatalities associated with tractors, especially among children and youth. Most tractors are designed for one person. If an instructional seat is built into the cab it is intended to be used to teach someone to be a tractor driver. Extra riders put themselves and the driver at risk. The extra rider is exposed to the same dangers as the operator. The extra rider distracts the operator when he or she is trying to concentrate on driving; can block access to control panels; and can obstruct the operator's view.

Falling from the vehicle is one of the most dangerous results of being an extra rider. An unexpected bump or turn can cause the rider to fall under the tractor's tires. Death can occur when the rider falls and the tractor's wheels or trailing implements run them over.

A tractor cab can give a false sense of security. Deaths and injuries can occur when the rider falls from an enclosed cab. Cabs can reduce, but not eliminate, the risk of harm.

Additionally, both the tractor operator and the extra rider can be exposed to health risks. The vibration of the tractor has the potential for jolting bones, muscles, and organs. The constant movement for the passenger, especially when traveling in bumpy fields, may have long term effects. The noise of a running tractor can damage hearing if exposure occurs for long periods.

The tractor can have a decibel level of 85 to 100 if the door is open which is comparable to loud rock music. Hearing protection should be used.

Dust from working in the field can filter into your lungs while you breathe. Extended exposure to dust, pesticides, or other particles can lead to respiratory damage. Wear a respirator mask when appropriate.

Tractors are designed for work, not passenger transportation. Walk, ride a bike, or ride on the inside of a pickup cab with a seatbelt, if you have to get from one location to another. Make a lifetime policy to never allow extra riders on tractors. When old enough to drive a tractor be smart, use caution, and refuse to allow your friends to ride on a tractor with you. Place warning decals on the tractor fender to remind everyone of the dangers of riding on a tractor.

Parents and adults can help prevent injuries among youth by following these rules:

- ▶ Do not allow anyone to ride with tractor operators.
- ▶ Model safe behavior by not riding as a passenger unless in a training setting.
- ▶ When an instructor seat exists, follow all safety guidelines set forth by the manufacturer.
- ▶ Place warning decals on all tractors.

MECHANICAL HAZARDS

Tractors, like many machines on the farm, perform functions that can be dangerous if safety precautions are not followed. The chart on page 10 lists specific hazards, an explanation of the hazards, and ways to prevent injuries.

Activity: Use the information in the chart on page 10 to complete the Mechanical Hazards Match Up on page 58 in the puzzle section.

The leading source of fatal injuries to youth (23%) involves machinery, including tractors. Young youth may not be directly involved with these hazards but they need to know the potential risks around tractors. If you see a warning sign, stay away from the machine. Decals and symbols identifying hazards are often placed on the tractor (see examples below).



Question & Answer

Q: What should you do if you see that a guard is missing on a rotating object such as a PTO or a fan blade on the tractor?

A: Do not go near the object, especially if it is running. You could get caught in the spinning mechanism. Tell an adult about the missing guard.

Q: Why are pictures used to identify different mechanical hazards?

A: In a situation where there are potential hazards, it is important to recognize the dangers quickly. Pictures are more easily and quickly recognized than written words. Images are universally understood in case operators cannot read English.

FALLS

Falls from tractors are common and preventable. Falls can take place from a moving or stationary vehicle or machine. Make sure all steps and platforms are clean and free from grease, ice, manure, water, and other debris. Slipping on these substances can cause a person to fall. Use hand rails and steps when climbing aboard or down from the tractor. Wearing slip-resistant shoes will also help prevent falls.

Jumping from a tractor, whether it is moving or not, can be dangerous. Clothing items can get caught on levers or other protruding parts causing the tractor to lurch into motion. Broken bones can result if you land incorrectly. If the tractor is moving, the operator can fall in the path of trailing implements which can cause death.

When operating a tractor with a rollover protection structure (ROPS) use a seatbelt to protect yourself. Never try to get off the tractor while it is moving, even when it is moving very slowly.

Use hand rails and steps, facing the tractor, when climbing aboard or down from a tractor. High speeds can cause the operator to fall from the tractor, especially if turning corners sharply or driving over obstacles.

Fall prevention tips :

- ▶ Wear slip-resistant shoes.
- ▶ Keep steps and platforms clean and free of grease, ice, manure, and water.
- ▶ Use hand rails and steps when getting into and out of the tractor.
- ▶ Do not jump from or exit any moving vehicle.
- ▶ Wear a seatbelt when operating a tractor with a ROPS.

Question & Answer

Q: What is the worst thing that could happen if you fall off a tractor?

A: Death can occur if you fall off the tractor while it is moving. A tractor can weigh several tons. If you get run over by the tractor tire, you could be crushed.

Q: As a youth, what things can you do to prevent falls from tractors?

A: Clean manure and other debris off tractor steps; refuse to ride on a tractor as a passenger; and wear slip-resistant shoes, if operating a tractor.

Q: What type of clothing should be worn when driving tractors?

A: Close fitting clothing without dangling strings or flapping cloth will help prevent getting caught in moving parts or tripping. Wearing slip-resistant shoes will help prevent falls.

SMV emblems are used to help other vehicles see tractors from a distance. These brightly colored, reflective triangles are placed on the back of the tractor and implements so they can be seen from a distance and vehicles have time to slow down.

Tractors and the implements they might pull are wide, often wider than one lane. Tractors cannot always use the road's shoulder because of unsafe road surfaces or road obstacles such as mailboxes.

Question & Answer

Q: If you are riding in a car or truck with your parent on a rural road what can you do to help keep your family safe?

A: Remind the driver to slow down to prevent collisions with slow moving vehicles. Point out that hills and curves can impede their line of sight where tractors may be moving at a much slower pace.

Q: An extra rider on a tractor driving down the road is at risk and so is the driver. What safe mode of transportation should be used instead?

A: Ask a licensed driver to take you to your destination in an automobile, ride a bicycle, or walk.

TRACTOR ROADWAY USE

Tractors and other vehicles must share the road. During busy seasons, many tractors and implements are being transported from one location to another. Tractors travel at a much slower speed than motor vehicles like automobiles, pickups, and trucks. This difference in speed can create problems for both vehicles, especially combined with the characteristics of rural roads such as hills, gravel, narrow shoulders, decreased visibility at corners, and steep grades.

The short closure time of a fast approaching vehicle behind a slow moving tractor often does not give the driver of the faster vehicle time to react.



Mechanical Hazards

Hazard Name	Explanation	Dangers	Prevention
Pinch Point	Two parts move together and there is a possibility that a body part could be caught between them.	Body parts that get caught can be cut or crushed; loose clothing that gets caught can pull body parts into the mechanism.	Stay away from moving objects. Keep shields in place.
Wrap Point	Rotating components, such as a PTO.	Clothing caught by the spinning shaft can pull a person into the mechanism.	Keep shields in place and shut off power before approaching the mechanism.
Shear Point	Two machinery parts move across each other.	An object in contact with the metal parts can be cut.	Turn off machine before approaching.
Crush Point	Two objects moving toward each other or one moving object hits a stationary object.	Body parts can be crushed by the moving part or dropped item.	Do not stand in a position where you could be caught and block all joints so the object can not move.
Burn Point	Heat from hot objects can burn flesh.	Hot mufflers, pipes, and hydraulic fluids can burn a person.	Do not touch the engine or other potentially hot objects. Carefully place your hand near the object to feel if it is warm.
Pull-in Point	Rotating objects that come in close contact with each other.	Rollers can pull a person into the mechanism.	Shut down the machine before making repairs or adjustments.
Stored Energy	Energy released when an object is unconfined, for example, a pressurized system.	Released energy or pressure has enough force to damage the body, if struck.	Avoid areas where spring loaded devices are present. Stay away from hydraulic hoses.
Thrown Object	Blades and other rotating devices can propel objects that come in contact with the spinning blade.	Objects that hit people have the potential to bruise, lacerate the skin, or deeply cut flesh.	Wear eye protection around rotating blades. Keep bystanders away.

Safety Features

ROLLOVER PROTECTIVE STRUCTURE (ROPS)

One of the key safety features on a tractor is the rollover protective structure (ROPS). When ROPS are used along with seatbelts they can virtually eliminate death and serious injury. Unfortunately, only half of the approximately 4.7 million agricultural tractors in the United States have ROPS. In 2012, 59% of tractors used in the US were equipped with ROPS.

Since ROPS were introduced to the general public in the 1970s, many lives have been saved during tractor overturns. Rollover protective structures are designed for each specific tractor and must meet national and international standards. ROPS protective frame and crush resistant cab, when used in conjunction with a seatbelt, can reduce the number of serious and often fatal injuries to tractor drivers. The seatbelt holds the operator within the protective frame if an overturn takes place. When used with a seatbelt, a ROPS is 99% effective in preventing deaths in tractor related incidents.

ROPS are either a two-post type or built within an enclosed cab when manufactured. The two-post type can be either rigid or foldable which have hinges to allow it to fold down for low clearance areas.

Most overturns are associated with farm-related activities such as driving over hazards like rocks, stumps, and holes; running into ditches; hitching high on the tractor when pulling implements; driving up steep slopes; and operating front-end loaders.

A person riding with the tractor operator, even in a tractor with a cab, is not fully protected by ROPS, especially if not wearing a seatbelt. Extra riders have been thrown against a door, releasing the latch and being ejected from the cab. Often these types of incidents result in the rider's death.



Overturn injury prevention tips:

- ▶ Wear a seatbelt while operating a tractor with a ROPS.
- ▶ Install factory made ROPS on tractors. Homemade ROPS may not provide the needed support if an overturn takes place.
- ▶ Take special caution when operating a tractor on a bumpy and sloping surface.
- ▶ Keep foldable ROPS up during operation.

Question & Answer

Q: What should you do if you come upon a person that has just experienced a tractor overturn?

A: Get help as soon as possible. Call 911 from the closest phone and give explicit directions to the location.

SLOW MOVING VEHICLE (SMV) EMBLEMS

Every tractor and self-propelled farm vehicle that uses the public roads at a speed less than the normal speed of traffic (most states define this as under 25 MPH) should have a slow moving vehicle (SMV) emblem. Check with your state department of transportation to determine your state's speed limit requirements. Towed implements may need the same type of emblem. SMV emblems are made of specially-designed, reflective material that is visible from a great distance. The emblems can be seen during the day and become even more bright when motor vehicle headlights shine on them at night.

SMV emblems are to be placed in the center of the tractor or implement and should be fastened between 2 to 10 feet above the roadway. They must be visible from a distance of at least 150 meters. SMV emblems fade in time due to sun and weather exposure. When this happens, replace the SMV emblem. When the SMV emblem becomes dirty, wash it.

Activity: Complete the SMV emblems activity on page 25 in the lesson plan section to learn about the reflexivity of these signs.



Question & Answer

Q: Why are the colors of florescent orange and red used on slow moving vehicle emblems on the back of the tractor?
A: These colors are highly visible during daylight hours. At night, the dark red border creates a hollow, red triangle which is very reflective when headlights from other vehicles hit the emblem.

Q: What can you do to increase the visibility of SMV emblems so your family’s tractor is noticeable while driving on public roads?
A: Wash the SMV emblem with soap and water to remove dirt and other road debris.

LIGHTING

Lights on tractors are required from one-half hour before sunset to one-half hour after sunrise. During this time period, the tractor operator cannot see clearly to drive and other vehicles cannot see the tractor. Tractors must have sufficient lighting that can be seen from a distance of 1,000 feet. A white light in the front of the vehicle is required. On the back of the tractor, there should be two red lights as wide as the machinery and on the highest part of the tractor there must be two flashing, amber lights. These lights are in addition to the SMV emblem on the back, middle section of the tractor.

Question & Answer

Q: What might happen if the lights on a tractor are not working?
A: Other vehicles on the roadways could not see the tractor at night and may collide with it.

FIRE EXTINGUISHERS

Friction and fuel combustion of dried plant material can lead to a fire on tractors. Small, portable fire extinguishers are available for use on the tractor if a fire should start. It is important to have a multi-class, most commonly an ABC, fire extinguisher. See the chart below.

Class	Symbol	Type of Fuel
A	Green triangle	Ordinary, combustible (i.e. plant foliage)
B	Red square	Flammable liquids and fuels
C	Blue circle	Electrical equipment
D	Yellow star	Combustible metals

Question & Answer

Q: As a youth, how can you protect your parents if a tractor fire should take place?
A: A multi-purpose fire extinguisher would make a great Christmas or birthday gift for your parent, grandparent, or guardian.

Q: Which class of fire extinguisher would probably not be needed on a tractor?
A: Class D (yellow star) would probably not be needed on a tractor. The other types of fuel are integral to tractor operation and therefore could start a fire.

While having a fire extinguisher aboard all tractors is a great asset, some upkeep is required. Be sure to check the expiration date, recognize that the pressure gauge needle is within the green area, and pressure test fire extinguishers every 5 to 6 years.

PRE-OPERATIONAL TRACTOR CHECKS

A pre-operational check of the tractor done by an adult will help ensure that mechanisms on the machine are working properly and safely. A safety “walk around” will identify items around the tractor that need to be addressed before operation. Make sure the tires are not frozen to the ground or stuck in mud. Remove any loose items such as tools laying on the tractor or platform. Check for any obstacles such as toys, large stones, or boards that may be run over if the tractor begins moving. Many of these items cannot be seen from the operator’s seat. It is especially important to make sure no children or other bystanders are present.

After doing the “walk around” it is now time to check the operating features of the tractor. Check these specific items on the tractor:

- ▶ Check for damage and proper inflation of tires. The tractor manual should give you inflation information.
- ▶ Clean windows for visibility.
- ▶ Rear view mirrors should be in the correct location for the operator. Adjust if needed.
- ▶ Make sure the seat is in the proper setting for the operator. Adjust the seat if it needs to be moved. Seatbelts should be in working order.
- ▶ Lights are working properly and are clean of mud and debris.
- ▶ Check the oil level. If oil is needed, avoid anything that would contaminate the oil while refilling.
- ▶ Make sure a working fire extinguisher is on the tractor.
- ▶ Check fuel level and radiator fluid level.
- ▶ Make sure the ROPS is up if it is a foldable version.

It cannot be emphasized enough that checking for people around the tractor is essential to prevent runovers. While in the driver’s seat, the operator may not be able to see or hear others on the ground, especially if they are small children. There have been many fatalities due to children playing close to the tractor or trying to approach the tractor operator.

Question & Answer

Q: What can children do to help ensure the safety of tractor drivers?

A: The best way children can help everyone be safe is to stay away when someone is performing a tractor check. An adult may not see a small child that gets in the way or could be distracted from his/her work.

TRACTOR MAINTENANCE

Tractors, like any machine or vehicle, need regular maintenance to keep them running smoothly and safely.

Operating and repairing tractors is an adult responsibility, but youth can help by telling someone about problems they may observe on a tractor. Often when tractors are being repaired, they are jacked up and wheels are removed. This process can be dangerous to the worker and anyone close. All children and other bystanders should keep their distance.

Youth can help with tractor maintenance by:

- ▶ Tell an adult if you hear any unusual noises.
- ▶ Remind adults working on repairs to turn off the engine before refueling, servicing, or greasing the tractor.
- ▶ Remove grease, oil, mud, and manure from steps and tractor platforms to prevent falls.
- ▶ Stay away from the tractor when it is being repaired. If youth stand too close, they put themselves in danger and distract the person doing the repairs whom is at even greater risk of injury.
- ▶ Report any missing guards and shields to adults so they can be replaced.
- ▶ Allow a trained person to do repairs instead of trying to do them.



Question & Answer

Q: Why should tractor repairs be done by an experienced person?

A: Tractors are valuable farm equipment and need to be protected from inappropriate actions that could cause damage. The mechanics of the tractor can be complicated. Someone with experience and knowledge should be conducting repairs and maintenance to protect the machinery and the individual from harm.

Q: What are some other things that might be found when conducting a tractor pre-operational "walk around"?

A: Items laying on the ground, such as tools that have fallen off the tractor or bolts that are not securely in place, may be found and should be repaired before operating the tractor.

TRACTOR STABILITY

A tractor's stability can be altered by a change in its center of gravity (COG). COG is the point where weight is most evenly distributed.

Tractor overturns usually occur when driving on a slope, over bumps, too fast, or using a front end loader. It happens when the COG is altered too much and the tractor tips beyond a point of no return.

To demonstrate COG, try balancing a pencil on your finger. When the pencil balances without falling, its weight is evenly distributed. If weight is attached to the tractor, or the tractor is hauling heavy items such as large, round hay bales, the center of gravity is altered just like adding a heavy eraser to the end of the balancing pencil.

Activity: Complete the Tractor Stability activity on page 35 in the lesson plan section.

Question & Answer

Q: What precautions can be taken to prevent injuries due to a tractor overturn?

A: ROPS protect the tractor driver but not an extra rider if they were on the tractor. Seatbelts hold the driver within the protection zone provided by the ROPS. Driving slowly around curves, on hills, and rough terrain will help prevent overturns.

Q: Why is it important to understand the center of gravity concept before operating a tractor?

A: It will help the driver operate the tractor more cautiously over bumps, on slopes, and encourage them to adjust speeds.



Equipment/Implements

FRONT END LOADERS

Front end loaders are used quite extensively on many farms to transport feed, gravel, manure, soil, and other items. The heavy load at the front of the tractor alters the center of gravity and the stability of the vehicle. This can lead to a tractor overturn if the operator does not know how to correctly compensate for the change in weight distribution. If the loader bucket is too high, unsecured materials in it can fall and injure the driver.

To safely use a front end loader:

- ▶ Keep the loader in the lowest position possible while transporting items. This will keep the center of gravity low and is less likely to reduce stability. Consider adding a ballast weight to the back tires.
- ▶ Driving on rough terrains, over obstacles, and on sloped surfaces increases the chance of tipping. When approaching these obstacles, avoid them if possible and slow down.
- ▶ The weight in the bucket adds to the momentum of the tractor. When turning a corner this momentum can cause the tractor to tip. Slow down and keep the loader low.
- ▶ Evenly distribute the weight within the bucket. An uneven load shifts the center of gravity.
- ▶ If the loader is not being used, remove the loader from the tractor. When the loader is attached it reduces visibility and makes it more difficult to maneuver into tight places.
- ▶ Do not use the loader as a work platform.
- ▶ Never walk under a raised loader bucket.
- ▶ Watch for overhead electrical lines when the loader bucket is in the up position. Coming in contact with electrical lines can cause electrocution.
- ▶ Always lower the bucket to the ground before parking the tractor. Remember, low and slow!

Question & Answer

Q: What precautions should youth take when in close proximity to farm implements?

A: Due to the size and weight of farm implements, everyone should stay away from any moving equipment. The loader bucket could fall or its load could be released so never stand in front of or under front end loaders.

TOWING IMPLEMENTS

In many locations there are no restrictions on the number of wagons or trailers being towed at one time by a tractor. The tractor driver is responsible for making sure the implements are securely connected to the tractor. This may require the use of a safety chain to attach the tractor and implement when on the road.

Question & Answer

Q: You may be asked to line up and attach an implement to a tractor. What precautions should you take to prevent injuries?

A: Say no, you're too young to hitch an implement to a draw bar. Parents can check with the North American Guidelines for Children's Agricultural Tasks (NAGCAT) to determine a child's ability to safely perform this task.



PTOS

Power Take-Offs (PTO) are used on the farm to transfer power from the tractor to another implement such as a grain auger, manure spreader, mower, or feed grinder. They are found on most tractors. PTOs operate by turning at speeds of 540 or 1,000 rotations per minute. This speed and the device make the PTO very dangerous. An entanglement can occur in the driveline between the tractor and the implement and can cause some of the most serious injuries on the farm. Equipment manufacturers provide shields for PTO drivelines to protect operators and bystanders from becoming entangled in the rapidly spinning shaft.

PTO Related Injury Prevention

- ▶ Make sure all PTO shields are in place and in good condition.
- ▶ Never step over a PTO while it is running, even if it is shielded.
- ▶ Do not wear jewelry or loose clothing, and tie long hair back so these items cannot come into contact with any part of the PTO.

Question & Answer

Q: Why can a PTO be dangerous?

A: The speed of the spinning shaft makes it hazardous because if something gets caught in the shaft it can pull body parts into the spinning shaft.

Q: How do you know if a PTO shield is properly installed and intact?

A: Never go near a rotating PTO whether it is shielded or not. When looking at a shielded, non-operating PTO, you should not see the rotating shaft, protruding screws, or jagged edges. Tell a parent or adult if you see any of these safety hazards.

Education/Training

Tractors come with operator's manuals intended to help the operator become familiar with the controls, gauges, and maintenance as well as safe operating procedures to be followed. All family members should know how to turn off the tractor and other equipment. Keep the manual in a convenient location on the machine for quick reference. If the manual has been lost, contact the manufacturer and request a new one.

Training and education are needed to drive a tractor safely. A tractor is a very powerful machine and should be treated with respect. Many youth are allowed to operate a tractor at a young age. It is important that they have the knowledge, skills, and abilities necessary to prevent injury and death. The North American Guidelines for Children's Agricultural Safety and Health (NAGCAT) have been established to help parents recognize the characteristics needed before children are assigned jobs on the farm, like operating tractors.

The US Department of Labor determined tasks which youth, ages 14-15 years old can legally perform for hire if certified. Certification courses are available to teach youth to be safer and more skilled tractor and machinery operators on the farm. Classes are taught by Extension personnel or agricultural educators. Call the local Extension office to find classes offered in your location. State and federal laws restrict youth from being employed to carry out certain hazardous activities or require certification to work off the family farm as well. These restrictions do not apply to youth working on their own farm but the necessary safety precautions do. Simply completing the recommended course work does not ensure the safety of young tractor operators. Supervision by a safety-minded adult is a must, especially when novice youth are first learning to operate the tractor.



The US Department of Labor identifies specific types of farm and ranch work that are classified as particularly hazardous for youth working under the age of 16.

These hazards include:

- ▶ Driving a tractor over 20 horsepower
- ▶ Operating general machinery such as corn pickers, cotton pickers, etc.
- ▶ Specialized machinery
- ▶ Livestock
- ▶ Wood lot
- ▶ Ladder and scaffold
- ▶ Transport
- ▶ Toxic atmosphere
- ▶ Chemicals
- ▶ Blasting
- ▶ Fertilizers

Employers can be fined if they hire youth under 16 to do these hazardous jobs if they have not successfully completed a certification course.

Activity: Complete the Agricultural Hazardous Tasks activity on page 21 in the lesson plan section.

Question & Answer

Q: What other situations impair a person's ability to safely operate a tractor.

A: (1) Using alcohol or drugs impairs the operator's ability to think clearly and slows down the reaction process when unforeseen situations take place. (2) Having other people riding with the tractor operator distracts the driver and may cause him or her to lose concentration when driving. If an unforeseen situation takes place (hit a hole, tire blows, run into a rut, etc.) the driver may not be capable of quickly and safely handling the situation. (3) Lack of knowledge and experience handling tractors may cause incidents if the operator does not have an understanding of what to do in the case of an unforeseen situation.

Evaluation

Conducting surveys of your intended program audience can identify their knowledge about tractor safety. If the surveys are done before an educational program takes place, it will give the presenter a basis for where his/her audience is in relation to tractor safety. The educational program can then target issues lacking by the audience.

The surveys can be conducted again after the program has taken place in a pre and posttest format. This will identify change in knowledge. The resulting information could make a great newspaper article when reporting the changes made by your audience.

Listed on page 19 are questions related to the information in this packet. Take into consideration what topics you plan to cover in your presentation and program. If you will not be covering hydraulics, don't use the questions related to this topic. The questions can be combined or rewritten to be specific to your program.

Surveys can be completed and tabulated several ways. They can be copied, distributed, completed, collected, and tabulated by hand if there are only a few surveys. If many surveys will be completed, an easier way to complete the process is using an electronic software package; some of them are free if you want only basic analysis results. Use their suggestions to ensure a good response rate.

ANSWER KEY: 1:b, 2:a, 3:d, 4:d, 5:d, 6:c, 7:b, 8:a, 9:c, 10:b, 11:c, 12:a, 13:d, 14:b

SELF-ASSESSMENT

The self-assessment tool can be used to identify behaviors used by your audience. If used before your presentation, it can be used to identify areas that need special attention. If used after the program, it can be used to see if your audience has changed their behavior when compared to the assessment done prior to the program. This information is self-reported so there is a chance the information may be slanted.

Student Self-Assessment of Safe Behavior When Around Tractors

	Always	Sometimes	Never
I do not allow passengers when operating a tractor			
I do not ride with others when they are operating a tractor			
I model safe behavior around tractors when children are present			
I place warning decals on tractors			
I have successfully taken a tractor certification course			
I do not step over an operating PTO shaft			
I report when a shield is defective or missing			
I clean tractor steps and platforms when dirty			
I clean dirty SMV emblems			
I report when SMV emblems are faded			
I use hand rails and face the tractor when climbing aboard			
I do not jump from or exit a moving vehicle			
I tell an adult about strange noises made by the tractor			

1. What is the most often used equipment on the farm?
 - a. Combine
 - b. Tractor
 - c. Grinder
 - d. Saw
2. What are the leading causes of fatalities to children on the farm?
 - a. Tractor related incidents
 - b. Livestock related incidents
 - c. Chemical related incidents
 - d. Grain related incidents
3. When people experience a tractor related incident they are hurt physically. What are other consequences?
 - a. Property damage
 - b. Medical bills
 - c. Loss of work time
 - d. All of things can occur
4. When operating a tractor what can you do to help prevent a side overturn?
 - a. Use side mounted implements
 - b. Turn into the slope
 - c. Drive close to ditch and embankment edges
 - d. Avoid rough surfaces and pot holes
5. When are tractor overturns more likely to take place?
 - a. When brakes are applied to decrease speed
 - b. When a sudden uphill turn takes place
 - c. When driving out of mud or ice
 - d. All of the above
6. What can be done to help prevent injuries involving hydraulics?
 - a. Leave the engine on when servicing the mechanisms
 - b. Check for leaks in the hydraulic lines with your finger
 - c. Wear safety glasses when checking hydraulic lines
 - d. Support the implement with the hydraulic cylinder
7. Being an extra rider on a tractor can cause physical injury. What other health hazards can occur?
 - a. Vibration of the tractor can cause hearing loss
 - b. Noise from the tractor can cause hearing loss
 - c. Dust can be inhaled into the circulatory system
 - d. All of these can cause health hazards
8. Which of the following would be a way to avoid tractor related injuries?
 - a. Wear slip-resistant shoes
 - b. Climb down facing away from the tractor
 - c. Wear a seat belt on a tractor without a ROPS
 - d. Jump from the tractor when dismounting
9. Rural roadways are dangerous. What are the reasons for this increased risk?
 - a. Tractors travel at a faster speed than cars
 - b. Tractors are easy to see around because they are small
 - c. Rural roads are often hilly and have narrow shoulders
 - d. Gravel and dirt surfaces make for clear vision for drivers
10. When an object falls on a person and injures them, it is called a...
 - a. Pinch point
 - b. Crush point
 - c. Pull-in point
 - d. Wrap point
11. Which of the following would help prevent an injury related to tractor operation?
 - a. Never wear a seatbelt when operating a tractor with a ROPS
 - b. Drive fast when operating a tractor on a bumpy or sloping surface
 - c. Never allow extra riders on the tractor
 - d. All of these will help prevent injuries
12. Which of the following statement is true about tractor lighting?
 - a. A white light on the front of the tractor and two red lights on the highest part of the back
 - b. An amber light on the front and white lights on the lower back
 - c. Red lights on the front and white lights on the highest part of the back
 - d. Blue lights on each side
13. What are things youth can do to help ensure safety of the tractor operator?
 - a. Report missing guards and shields to adults
 - b. Clean debris from tractor steps and platforms
 - c. Tell an adult when they hear unusual tractor noises
 - d. All of the above could help prevent tractor injuries
14. Which of the following are safe practices when around PTOs?
 - a. Wear loose clothing when near an operating PTO
 - b. Make sure shields are in place and in good condition
 - c. Be close to the PTO when it is operating
 - d. Save time by stepping over the PTO

Resource Listing

PARTNER SAFETY WEBSITES

Organization	Web Link	Content
US Department of Labor	http://www.dol.gov/whd/state/agriemp2.htm	Listing of state specific agricultural child labor laws
USDA Extension Service	https://www.extension.org	Listing of extension resources – search for tractor safety
National Ag Safety Database	http://nasdonline.org/	Listing of farm safety and health resources – type in tractor safety
CDC/NIOSH	http://www.cdc.gov/niosh/topics/aginjury/	Fact sheets
NIOSH Agricultural Safety and Health Centers	http://www.cdc.gov/niosh/oep/agctrhom.html	Projects and research about farm injury prevention, including tractor safety
Pennsylvania State University	http://extension.psu.edu/business/ag-safety/youth-safety/national-safe-tractor-and-machinery-operation-program	National tractor and machinery certification course material
Purdue University	http://www.gearingup.info	National tractor and machinery certification course material

REFERENCES

CDC/NIOSH. (2006). NIOSH awards funding to Ag Research Centers for initiative to reduce tractor deaths and injuries. Available at: <http://www.cdc.gov/niosh/NPPM/upd-03-21-06.html>

Donham, KD, Osterberg, M, Myers, M, & Letola, C. (1997). Tractor risk abatement and control. Policy Conference Final Report, 4-13. Iowa City, Iowa: University of Iowa.

Hard, DL, Myers, JR, & Gerberich, SG. (2002). Traumatic injuries in agriculture. *J. Agric. Safety Health* 8(1): 51-65.

Heaney, CA, Wilkins, JR, Dellinger, H, McGongle, H, Elliot, TL, & Jepsen, SD. (2006). Protecting young workers in agriculture. Participation in tractor certification training. *J. Agric. Safety Health* 12(3): 181-190.

Jenkins, PL, Sorenson, JA, Yoder, A, Myers, M, Murphy, D, Cook, G, Wright, B, Beyes, JJ, & May J. (2012). Prominent barriers and motivators to installing ROPS: An analysis of survey responses from Pennsylvania and Vermont. *J. Agric. Safety Health* 18(2), 103-112.

Jepsen, SD. (2012). The U.S. Department of Labor's tractor and machinery certification program: management styles and perceptions held by community stakeholders and instructors. *J. Agric. Safety Health* 18(3): 217-32.

NIOSH. (2014). Agricultural Safety. Available at: <http://www.cdc.gov/niosh/topics/aginjury/>

NIOSH. (2007). Injuries to youth on U.S. farm operations, 2004. Available at: www.cdc.gov/niosh/docs/2007-161/

NIOSH. (2004). National Agricultural Tractor Safety Initiative. E. Swenson, ed. Seattle, WA: University of Washington, Pacific Northwest Agricultural Safety and Health Center.

NIOSH. (2010). Worker safety on the farm. Available at: <http://www.cdc.gov/niosh/docs/2010-137/>

Ontario Farm Safety Association. (2002). A guide to safe farm tractor operation. Available at: <http://www.nasdonline.org/document/1659/d001534/a-guide-to-safe-farm-tractor-operation.html>

Penn State Extension. (2014). National safe tractor and machinery operation program. Available at: <http://extension.psu.edu/business/ag-safety/youth-safety/national-safe-tractor-and-machinery-operation-program>

Don't forget to utilize local insurance companies, farm equipment dealerships, safety videos on YouTube, and universities in your state.

Lesson Plans

Tractor Safety Attitude Continuum	Page 20
Working Youth	Page 21
Slow Moving Vehicle (SMV) Emblems	Page 25
Seatbelt Safety	Page 27
Drive Head Over Wheels	Page 29
Tractor Hazards	
Activity 1 - Moving Parts	Page 30
Activity 2 - Heat and Fire	Page 31
Activity 3 - Falling	Page 32
Activity 4 - PTOs	Page 33
Activity 5 - Hydraulic Safety	Page 34
Tractor Stability	Page 35

TRACTOR SAFETY ATTITUDE CONTINUUM

Concept: This activity investigates and clarifies participants' attitudes concerning children when they are around tractors. It helps participants discuss different views to sensitive issues in a nonthreatening format. Statements are designed to be progressively more controversial to foster discussion. If young children participate in this activity with their families, an adult may need to help them understand the concept of "level of agreement" and translate their answers into numerical values.

Targeted Age: Adults, families, and youth

Time: 30 to 45 minutes

Ask each participant to number from 1 to 9 (more or less if using different statements), on a piece of paper. Read the following statements out loud. After each statement, have each person place a numerical value from 1 to 10 as to their level of agreement. Ten equals the most agreement and one equals the least agreement.

Statements:

1. A pedal tractor was my favorite toy as a child.
2. Red is the best color to paint a tractor.
3. A child's father should teach him/her how to operate a tractor.
4. Most ten year olds are capable of driving a tractor safely.
5. All youth, whether driving a tractor on their own farm or as an employee, should be required to take a tractor driving class.
6. Tractor rides are a great way for a child to bond with a parent/grandparent.
7. A tractor with a cab provides sufficient protection for a child passenger.
8. Parents of a youth that died as a result of a tractor overturn should be held legally responsible for the death.
9. No youth should be allowed to be an extra rider on a tractor.

Explain that one wall of the room is a continuum with 1 at the far left and 10 at the far right. All other numbers fall in between. Taped numbers on the wall will help. With answers in hand, have participants walk to the number corresponding to their answer for number 1. Do not re-read the statement until everyone is positioned. Encourage people to be honest and not go with the crowd. Allow time for discussion after each statement. When you are finished with statement one proceed through the list until each statement is addressed and the students have moved many times along the wall.

This activity will spur good interaction and discussion about attitudes toward tractor safety. Explain that there are no right or wrong answers.

Facilitator – Ideas to be brought out during discussion:

- ▶ Differences about commonplace things are less likely to be controversial.
- ▶ Interpretation of a statement can be diverse.
- ▶ Individual backgrounds and attitudes influence behavior.
- ▶ People may have different opinions and still have common goals.
- ▶ Openness can lead to change.

WORKING YOUTH

Objective: Identify hazardous jobs on the farm that youth under the age of 16 should not be doing.

Concept: This activity is designed for youth before they start working on the farm. It is important for youth to know which farm tasks they should not be performing. The size, power, and mechanisms of tractors and farm machinery can cause injuries if proper precautions are not taken. Youth are at high risk; they do not have the size, strength, knowledge, and training necessary to safely perform certain tasks and operate specific machines.

Federal laws regulate that no youth younger than 16 years old perform specific tasks off the family farm without attending a tractor certification class. These tasks are shown in the pictures on pages 22-24. The laws only apply to situations where youth are employed for work. If youth are working for their parents the laws do not apply, although the identified situations and equipment are just as dangerous. It is wise for youth to stay away from dangerous situations no matter who they are working for.

Targeted Age: Junior high school students, parents, and employers of youth workers

Time: 30 to 45 minutes

Material: Pictures of tractors and farm machinery identified in the hazardous occupational act. (Larger, colored pictures can be found on the internet or in farm magazines.)

Identify agricultural dangers, especially those most harmful to youth. The items in the charts on pages 22-24 represent each of the dangers that are outlined by the US Department of Labor. Fill in the charts with the hazards associated with each item.

Discussion: Have students share stories that show how youth can become injured while performing dangerous tasks. Ask the students to explain how the person was injured (body part, injury severity, work setting, etc.). Give suggestions about preventing a similar incident.

Question & Answer

Q: Are there laws that prevent youth from being employed on a farm?

A: Yes, federal law states that youth under the age of 16 cannot work for hire performing some hazardous tasks.

Q: List jobs on the farm that aren't prohibited, therefore allowing youth to work for hire while doing these tasks.

A: Mowing lawns, picking berries, feeding hogs, repairing fences, loading hay, milking cows, painting, etc.

Q: There is a certification course that helps youth age 14 and 15 learn about working on the farm safely. What farm jobs can youth perform more safely because they took the certification course that otherwise they could not?

A: Youth can safely operate a tractor over 20 hp, combines, grinder, tillers, and other machinery because they took a certification course.

Q: Where can you find out about the certification course?





A: Call your local Extension office or FFA advisor and ask when and where the courses take place.

Q: The certification course targets what age group?

A: The course is designed for youth between 14 and 16 years old. Other youth can take the class for their own well-being or if their parents want them to learn how to be safer on the farm.





(this activity is continued on the next page)

WORKING YOUTH (CONTINUED)

	Identified Hazards	Why are youth at increased risk?
 <p>Tractor over 20 hp</p>	<p>Example: The power of a tractor is greater than most other vehicles on the farm.</p>	<p>Example: Youth often lack the knowledge and experience necessary to safely operate a large tractor.</p>
 <p>General machinery</p>		
 <p>Specialized machinery</p>		
 <p>Transportation</p>		





(this activity is continued on the next page)

WORKING YOUTH (CONTINUED)

	Identified Hazards	Why are youth at increased risk?
 <p>Livestock (male livestock such as bulls, boars, etc.)</p>		
 <p>Wood lot (logger)</p>		
 <p>Ladder and scaffold (higher than 20 feet)</p>		
 <p>Transport (tractor with passenger)</p>		

(this activity is continued on the next page)

WORKING YOUTH (CONTINUED)

	Identified Hazards	Why are youth at increased risk?
 <p>Toxic atmosphere</p>		
 <p>Chemicals</p>		
 <p>Blasting</p>		
 <p>Fertilizers</p>		

SLOW MOVING VEHICLE (SMV) EMBLEMS

Objective: Visualize the importance of clean, bright slow moving vehicle (SMV) emblems for tractors and other farm vehicles used on public roads.

Concept: Farmers often use public roadways to move large farm machinery and tractors from one location to another. Large farm equipment travels at much slower speeds than cars and pickups. SMV emblems are made of reflective materials and are attached to the back of farm machinery to alert faster vehicles to slow down in order to avoid a collision.

Targeted Age: Upper elementary school students and above

Time: 30 to 45 minutes

Materials:

- ▶ Orange reflective tape
- ▶ Red reflective tape
- ▶ Blue, green, orange, and red construction paper
- ▶ Flashlight
- ▶ Dirt or mud
- ▶ Optional: two SMV emblems (one new and one faded)

This activity should be done in a large room where you have the ability to turn the lights off and cover the windows with curtains or shades.

Cut various colors of construction paper into long, rectangular strips. Tape all strips of paper and similar strips of reflective tape on one wall of the room. Have all the students move ten feet away from the wall. Turn out the lights. Shine the flashlight beam on each object. Compare similar colors of different materials (red construction paper and red reflective tape). Compare different colors of the same material (red and orange reflective tape). Use additional colors (blue, green, etc.) to demonstrate why red and orange were chosen for the SMV emblem. Keep track of which colors and materials are the most visible. Turn on the lights and rearrange the strips in the order of least to greatest visibility. Have the students move as far away from the taped strips as possible. Turn out the lights again and shine the flashlight onto the strips. Compare the visibility. They should be in the order of least to most visible. If not, rearrange to reflect the group's choices.

Place mud on a part of each reflective strip and tape. Turn off the lights and observe what the mud does to the reflexivity of each strip. If you have new and old SMV emblems, repeat the demonstration comparing the faded and new emblems.

Discussion: Discuss various farm machinery using the public roads (tractors and implements, combines, etc.). Discuss the shape, size, and color of an SMV emblem. Discuss where the SMV emblem should be located on a tractor or farm implement (center; back of vehicle; high enough for car lights to shine directly onto emblem; from 2 to 10 feet off the road surface). The SMV emblem should be securely mounted with bolts so the surface is straight and perpendicular to the surface of the road.

(this activity is continued on the next page)

SLOW MOVING VEHICLE (SMV) EMBLEMS (CONTINUED)

Question & Answer

Q: Why are SMV emblems necessary on farm machinery?

A: Due to the difference in speed, a slower vehicle such as a tractor, needs to be visible from a distance in order for a faster vehicle to slow down and avoid a collision. To facilitate this, machines that travel less than 25 miles per hour need to have slow moving vehicle emblems on the back to increase visibility. Not all states have SMV regulations while some have different speed limits, so check your state laws.

Q: When driving a vehicle on the road, what should the driver do when they come up behind a tractor with an SMV emblem?

A: Farm vehicles are allowed on the traveled portion of a highway. The orange and red triangle is a signal to all drivers to slow down and be cautious. When you see it, reduce your speed and maintain a safe following distance. Only pass when it is safe to do so. Some farm vehicles are long and wide and may turn at places that are not well marked, such as field entrances, so be prepared to stop.

Q: When are you most likely to come across tractors and other farm machinery while driving on rural roads?

A: Farm machinery is most likely to be on the road during planting and harvest but they may be on the road at any time during the year.

Q: What things prevent an SMV emblem from reflecting properly?

A: It is important that the emblems are clean and in good condition. As SMV emblems age, they lose their reflective ability. Replace SMV emblems that are no longer reflective.

Q: What things can youth do to help keep the drivers of slow moving vehicles safe?

A: Notice when an SMV emblem becomes faded and loses its reflexivity. Ask an adult for help in replacing it with a new one. If the SMV emblem becomes dirty, wash it with soap and water. These actions can help prevent a machinery/vehicle collision. When riding in a vehicle, youth can inform the driver when they spot a slow moving vehicle on the roadway.

Q: Where is the slow moving vehicle (SMV) emblem placed on the tractor or implement? Which characteristics of an SMV emblem help to improve its visibility?

A: The SMV emblem is placed 2 to 10 feet above the road surface on the middle back of the tractor or implement. An SMV emblem must be highly reflective and clean. If not, other drivers sharing the road with the tractor cannot see the tractor early enough to slow down to prevent an accident.

Q: Why should SMVs NOT be used as driveway markers?

A: SMV emblems are intended for use on tractors and other farm machinery. If they are used in other situations to call attention to a specific area, their purpose of calling attention to a tractor is diminished.

SEATBELT SAFETY

Objective: Identify the importance of seatbelts on a tractor with a cab or ROPS.

Concept: Rollover protective structures (ROPS) provide a protective zone for the tractor's driver. A seatbelt holds only the driver (not any other rider) within the protective zone that the ROPS provides. If a seatbelt is not worn, the driver can be thrown outside this zone if the tractor rolls or goes over rough surfaces.

Targeted Age: Upper elementary school students and above

Time: 30 minutes

Materials:

- ▶ 2 toy tractors, one with a ROPS and an older model without a ROPS ($\frac{1}{16}$ size or larger)
- ▶ 5 or more uncooked eggs
- ▶ Markers or crayons
- ▶ Plywood to form driving surface, raise one end slightly and brace with spacers (books, cans, etc.)
- ▶ Tape
- ▶ Plastic drop cloth or large plastic garbage bags

Have the students draw faces on the egg shells using markers or crayons to represent people. They can name them, if desired. Place the drop cloth or plastic bag under a table where the demonstration will take place. Create a raised driving surface on a table with the plywood.

Place one egg on each seat of the tractors. Drive the tractors (one with ROPS and one without) from the raised end of the board holding the eggs in place until the tractor picks up momentum. Let go of the tractor and the egg. Notice what happens to the eggs (drivers) when the tractors roll off the table.

Repeat the demonstration. This time tape the egg securely in the tractor seat on both tractors (ROPS and no-ROPS). The tape represents a seatbelt. Roll the tractors again to build up momentum and release.

Attach another egg (extra rider) onto the fender of the ROPS tractor with tape. Drive the tractor off the table and see what happens.

Discussion: Look closely at both tractors. Have the students explain the differences they find between the two tractors. Discuss the size of a person that would be driving each tractor and if they would fit within the safety zone provided by the ROPS. Discuss where the person would land if the tractor rolls onto its side or backwards.

(this activity is continued on the next page)

SEATBELT SAFETY (CONTINUED)

Question & Answer

Q: Does anyone in the group know of someone who has experienced a tractor overturn?

A: Answers will vary. If a death has occurred, ask the person about the driver's age, the type of tractor they were driving, and what they know about the situation. Be sensitive especially if the person was a family member. If the driver survived, ask the speaker to explain which safety precautions saved his/her life.

Q: What is meant by a safe protective zone on the tractor?

A: The safe zone on a tractor is the area where the driver sits within the ROPS or cab. The ROPS or cab has reinforced steel that protects the driver in case the tractor rolls onto its side or backwards.

Q: Why is a seatbelt important when driving a tractor with a ROPS or cab?

A: In the case of an overturn, the driver must be held in place within the safe protective zone. When a tractor begins to tilt the driver loses balance and is thrown from his/her seat. They could very easily land in a place where the tractor could roll and crush them. This can happen even when the tractor has a ROPS or cab. When the tractor rolls the driver can be thrown off, if a seatbelt is not worn.

Q: Are there times when a seatbelt should not be worn on a tractor?

A: Seatbelts were not installed on tractors built without ROPS or cabs. If an older tractor without a ROPS is being used, do not have seatbelts retrofitted on them. Since there is no safety zone for the tractor driver, there is no reason to keep the driver in his/her seat. If the tractor overturns, the driver may be pinned under the tractor. If a tractor has a foldable ROPS, the seatbelt should not be used when the ROPS is not being used. Store tractors with foldable ROPS in the up position.

Q: Is there any safe place for an extra rider on a tractor?

A: No, there is no safe place for an extra rider on a tractor. Riders inside the cab should be limited to those providing training or machine diagnostics. The instructional seat is not intended or designed for use by children.

Q: What can be done for older tractors that were manufactured without ROPS?

A: Tractors can be retrofitted with a ROPS. Contact your local implement dealer and ask about a ROPS for your specific model. There is a national program associated with retrofitting a tractor, call 877-ROPS-R4U for more details. The University of Kentucky has a list of phone numbers to get ROPS. Visit: <http://warehouse.ca.uky.edu/rops/ropshome.asp>

DRIVE HEAD OVER WHEELS

Objective: Demonstrate safe driving practices using toy tractors.

Concept: Driving a tractor on an incline or on uneven terrain increases the dangers associated with operation. This is often the case when tractors are in operation on the farm.

Tractors are very heavy. If they become unbalanced when operating on sloped surfaces, this heavy weight shifts and pulls the rest of the tractor with it, possibly turning the tractor over. The steepness of the slope influences how likely the tractor is to tip.

Front tractor weights affect the center of gravity and help to keep the wheels on the ground when driving on hills.

Targeted Age: Upper elementary school students and above

Time: 30 minutes

Materials:

- ▶ 2 non-remote toy tractors, one with a ROPS and one with narrow, tricycle front tires without a ROPS (1/16 size or larger)
- ▶ 2 Plywood sheets to form 2 driving surfaces
 - One raised slightly (less than 10 degrees) and braced with spacers (books, can, etc.)
 - One raised steeply (greater than 15 degrees) and braced with spacers (books, can, etc.)
 - Flat surface at the top between the two braced inclines

Form two inclined driving surfaces with the plywood and risers. Place the flat surface at the top of the steep incline so the tractor can drive easily from the incline to the flat surface.

Allow the students to pass the tractors around and instruct them to pay attention to the weight distribution of each tractor. Drive each tractor up each

slope and compare the weight distribution when driving up the steep and slight slopes. Turn the tractors around and back up each slope. When backing up a hill the drive wheels are at the top, making it less likely to tip over. Drive one tractor on the ridge between the flat surface and the steep slope; this represents driving with one wheel in a ditch. Observe and feel which way the tractor pulls.

Discussion: Look closely at both tractors. Have the students explain the differences between the two tractors (size, cab or ROPS, weight, SMV emblem, etc.). Discuss how each item relates to safety.

Study the angle of the slopes represented by the plywood surfaces. Estimate the difference in the angles of the two slopes. Explain how the steepness of the slope impacts the stability and center of gravity of the tractor.

Discuss places on the farm where tractors have to drive on sloped surfaces (ditches, hills, etc.) and what the tractor may be doing (mowing, driving on hilly roads, etc.). Discuss the characteristics of the tractor that make it safer when driving on slopes (weights and ROPS).

Question & Answer

Q: Why is driving up a steep slope backwards a safe option?

A: By turning the tractor around the weight is redistributed. The back tires, especially if they are dual tires, are very heavy and are used for traction. When driving forwards up a hill, the front of the tractor may come off the ground, causing the tractor to tip over backwards. Weight is often added to the front of the tractor to counter balance the weight of the back tires. When driving backwards, you are moving the heaviest part of the vehicle first and therefore less likely to tip.

TRACTOR HAZARDS

Objectives:

- ▶ Comprehend the hazards associated with operating a tractor.
- ▶ Develop tactics that prevent injuries while operating a tractor.

Concept: Tractors are used extensively on most farms. These tractors range from small lawn tractors to large, powerful, highly specialized vehicles. All machines can be hazardous when they are operated improperly.

Hazard examples include:

- ▶ The tractor motor has many moving parts. The moving parts can cut, pinch, and crush body parts if not used properly.
- ▶ Fuel used to power the engine can ignite causing a fire.
- ▶ Tractors that are very large can create a long fall if a person slips from the top of the machine.
- ▶ The power of a tractor is often transferred to another implement by way of a power take-off (PTO). The spinning shaft of the PTO creates a hazard if anyone gets too close.
- ▶ If hydraulics are used, the hoses are under extremely high pressure and can be dangerous if they become undone.

Targeted Age: Upper elementary school students and above

ACTIVITY 1 - MOVING PARTS

Materials:

- ▶ Uncooked hot dog (several if all students participate)
- ▶ 3 foot x ¼ inch dowel stick (several if all students participate)
- ▶ Spinning wheel (bicycle wheel, fan blade, small motor, etc.)

Place the dowel stick into the hot dog lengthwise. Start the fan, motor, or bicycle wheel spinning. Holding the dowel close to the end opposite the hot dog, place the hot dog end into the blade. The stick represents a bone and the hot dog represents flesh. The motor or wheel represents the tractor motor.

Discussion:

Each year, people are hurt when they tempt fate by working around motors that are not shut off or shielded properly. Ask the students to list items on a tractor that can move quickly (motors, fan blades, auger, PTOs).

Question & Answer

Q: Where are fast moving parts found on the tractor?

A: The tractor motor has fan blades and belts that move quickly. Implements that are powered by the tractor often have fast moving objects. Augers, PTOs, and fans all fall into this category.

Q: What things can you do to prevent injuries from moving parts on a tractor?

A: Install shields over moving parts to prevent a person from getting caught. If a shield becomes defective due to age, it should be replaced.

Q: Which body parts are most likely to be hurt by moving parts on the tractor?

A: Fingers, feet, and hair are body parts most often caught in moving mechanisms.

Q: What can youth do to prevent injuries from powerful, moving parts?

A: If you see a missing shield, tell an adult so they can repair it.

TRACTOR HAZARDS

ACTIVITY 2 - HEAT AND FIRE

Materials:

- ▶ Various Fire Extinguishers
 - Class A – Ordinary Combustibles
(label showing a triangle)
 - Class B – Flammable Liquids
(label showing a square)
 - Class C – Electrical Equipment
(label showing a circle)
 - Class D – Combustible metals
(label showing a star)
 - Multi-Class Fire extinguisher
(pictorial representation of fire types)

Match up the shapes with the classes of fire extinguishers. Using a multi-class fire extinguisher, practice extinguishing a fire using the Pull, Aim, Squeeze, and Sweep system. Have each student practice putting out an imaginary fire to perfect the PASS system.

NOTE: If a professionally trained fireman is present, build a small fire in a self-contained trough and have the students use the fire extinguisher on a real fire.

Discussion: There are four types or classes of fire extinguishers, each of which puts out a specific type of fire. Newer fire extinguishers use a picture labeling system to show which type of fire the extinguisher will put out.

Question & Answer

Q: What could cause a fire to start around the tractor?

A: Flammable liquid fuel is present because it's used to power the motor. Harvesting dried plant crops, such as corn, beans, and hay can also produce a combustible fuel source.

Q: Which fire extinguisher would be the best to carry in the tractor?

A: There is no way to know how a fire might start on a tractor, so multi-class rated fire extinguishers are preferable.

Q: What is the best procedure to make sure a fire is put out?

A: PASS will help you remember the proper way to use a fire extinguisher:

- ▶ Pull the pin at the top of the extinguisher to release the safety lock.
- ▶ Aim the nozzle toward the base of the fire.
- ▶ Squeeze the handle to discharge the extinguisher (approximately 8 feet from the fire). If you release the handle, the emission will stop.
- ▶ Sweep the nozzle back and forth at the base of the fire. After the fire appears to be out, watch it carefully since it may reignite.

Q: What should you do if you notice that a fire has started around a tractor?

A: Tell an adult about the fire. Remind parents and adults to make sure fire extinguishers are working properly and they know how to use them.

TRACTOR HAZARDS

ACTIVITY 3 - FALLING

Materials:

- ▶ Ripe Cantaloupe (or other melon)
- ▶ Ladder
- ▶ Plastic tarp

Draw a face on the melon to represent a person's head. Using the ladder, climb to the top of a tractor cab, approximately 10 feet. Drop the melon onto the plastic tarp on the ground below.

Discussion: Tractors and other farm machinery are tall. If farm equipment is available, estimate how many feet off the ground the driver's seat or the platform are located. Compare this to the number of stories or windows in a building. Talk about an instance where people have accidentally fallen from these heights.

Question & Answer

Q: How tall is a large tractor?

A: Large tractors can be up to 10 feet tall. Combines can be even taller.

Q: What part of your body is the most vulnerable during a fall?

A: The head is the most vulnerable. If your skull is broken or cracked, the brain could be damaged. While other bones and muscles can heal, the brain is not easily repaired.

Q: How can you prevent falls from tractors and farm machinery?

A: Ladders and platforms used to access the driver's seat need to be kept free of slippery substances such as water, ice, grease, and manure. When using the ladder and platform, be sure to use the hand rails. Always face the tractor when mounting and dismounting, using the hand rails. Dismounting facing forward may result in falling face first.

TRACTOR HAZARDS

ACTIVITY 4 - PTOS

Materials:

- ▶ Tyvek coveralls (a balloon can be attached to the collar to represent a head)
- ▶ Straw or paper for stuffing
- ▶ Working tractor and attached PTO
- ▶ Hazard tape
- ▶ String

Stuff the coveralls with straw or paper to represent a person's body. An inflated balloon or Nerf ball can be attached to the coveralls to represent the human head. Make sure the PTO is in proper working condition.

Attach the stuffed "dummy" to the PTO shaft with a hidden string. (If you hold the dummy over the rotating PTO shaft it might not catch.) Do not allow youth to stand close to this demonstration. Create barriers using colored hazard tape to keep youth at least 10 feet from the demonstration. Have several adults present to make sure youth stay behind the barrier. Start the tractor and PTO. The dummy will begin spinning around the shaft. Stuffing may fly out of the Tyvek suit.

Discussion: Discuss why PTOs are used and the dangers that exist when the shaft is spinning. Discuss why shields are used to cover the PTO shaft and ways to identify when a shield needs replacing (cracked, bent, or missing areas, and protruding points).

Question & Answer

Q: What type of implements are powered by a running PTO?

A: Manure spreaders, augers, mowers, choppers, balors, and grinders, etc.

Q: How does the PTO transfer power from the tractor to the implement?

A: The tractor spins a metal shaft around very fast. This speeding circular action causes the mechanisms within the implement to rotate.

Q: How fast does a PTO shaft spin while it is working?

A: Depending on the power of the PTO, it could spin at 540 RPM or 1,000 RPMs (revolutions per minute). At 540 RPM the shaft is rotating 9 times per second. Our normal reaction time is 3/4 of a second - that means anything caught would wrap 6 times around the shaft before we realize it. The speed is dependent upon the power of the tractor and the implement that it is running.

TRACTOR HAZARDS

ACTIVITY 5 - HYDRAULIC SAFETY

Materials:

- ▶ Garden hoze with a nozzle
- ▶ Water source with a faucet
- ▶ Sunny day

With the nozzle closed, fill the hose with water. Turn the water off at the source. Let the hose set in the sun for several hours. When the hose feels hot, open the nozzle and notice the force of the water. After the initial hot water in the hose is released and the pressure is relieved, the water flow should subside.

Discussion: Tractor hydraulics are used to move or lift heavy items. The built up pressure is the force that causes the action. The term "hydraulic" refers to fluids under pressure. In the demonstration, the water is the fluid but since water becomes steam at 212 degrees Fahrenheit, it can not be used within a hydraulic system because it cannot build up enough pressure.

Question & Answer

Q: What fluid is used in a tractor's hydraulic system?

A: Oil is used. Oil has a much higher boiling point than water.

Q: How can tractor hydraulics be dangerous to a tractor operator?

A: The oil is under very high pressure, up to 3000 pounds per square inch. A leak in the hose could force oil under your skin and act like a poison. The heat generated by the pressure can also burn the operator.

Q: What precautions should be taken when using hydraulic components?

A: Wear gloves and safety glasses when working with a hydraulic system.

TRACTOR STABILITY

Objective: Determine the relationship between a tractor's center of gravity, weight distribution, and overturn potential.

Concept: Tractors are used extensively on the farm. Front end loaders, hay forks, and scoops allow farmers to lift very heavy items. When lifting heavy objects, the center of gravity shifts on the machine. This shift can cause tractors to overturn. Gravity is the pulling force between two objects due to their masses. Center of gravity (COG) is the balance point of objects.

Targeted Age: Middle school students

Activity 1

Materials:

- ▶ Card board
- ▶ Scissors
- ▶ 3 to 6 feet of string
- ▶ Tacks
- ▶ Ruler
- ▶ Pencils with unused erasers
- ▶ Tape

Make several copies of the tractor, loader bucket, and hay fork for each student (see pages 36-37). Instruct each student to glue the pictures onto the cardboard. Do the same thing with the large, round hay bales. Cut out the cardboard objects.

Attach a tack to both ends of a piece of string. Tack the top of the string into a bulletin board. Attach the second tack into the cardboard cut out of the tractor and allow it to pivot freely. When it comes to a rest, draw a line on the cardboard under the string.

Remove the tack from the cardboard and place it in a different location. Repeat. All the lines should meet at the same point. The meeting point marks the object's center of gravity. To expand on this concept, ask the kids to balance the cardboard cut out on the flat pencil eraser. It will only balance at the center of gravity. Repeat the demonstration using the remaining attachments.

Use tape to attach the loader bucket or a hay fork to the tractor in various positions. Tape a bale to the loader arm and identify the new center of gravity using the ruler, string, and tacks as before.

Compare the intersecting points. Notice the center of gravity changes as the weight distribution changes. Discuss the extra weight of the object being moved and how this alters the center of gravity.

Allow the students to try various weights and various height positions to determine the change in the center of gravity.

Activity 2

Refer to Drive Head over Wheels activity on page 29. Using a tractor with a front end loader, compare various objects in the loader and bucket height to identify when the tractor is most stable and when it is most likely to tip over.

Discussion: Discuss the relationship between the center of gravity and overturns.

Question & Answer

Q: When is a tractor most likely to overturn?

A: A tractor is very large and heavy. If the weight of the tractor is off-balance and starts to tip, it is difficult to stop the roll. Very similar to a snow ball picking up speed as it rolls down a hill, a tractor is hard to stop once it becomes off balance. Tractors can become off-balance when they are operated on hills, ditches, or rough surfaces.

Q: When using a front end loader on a tractor, what is the safest position for the bucket?

A: Always keep the bucket low when possible.

TRACTOR STABILITY (RESOURCES)

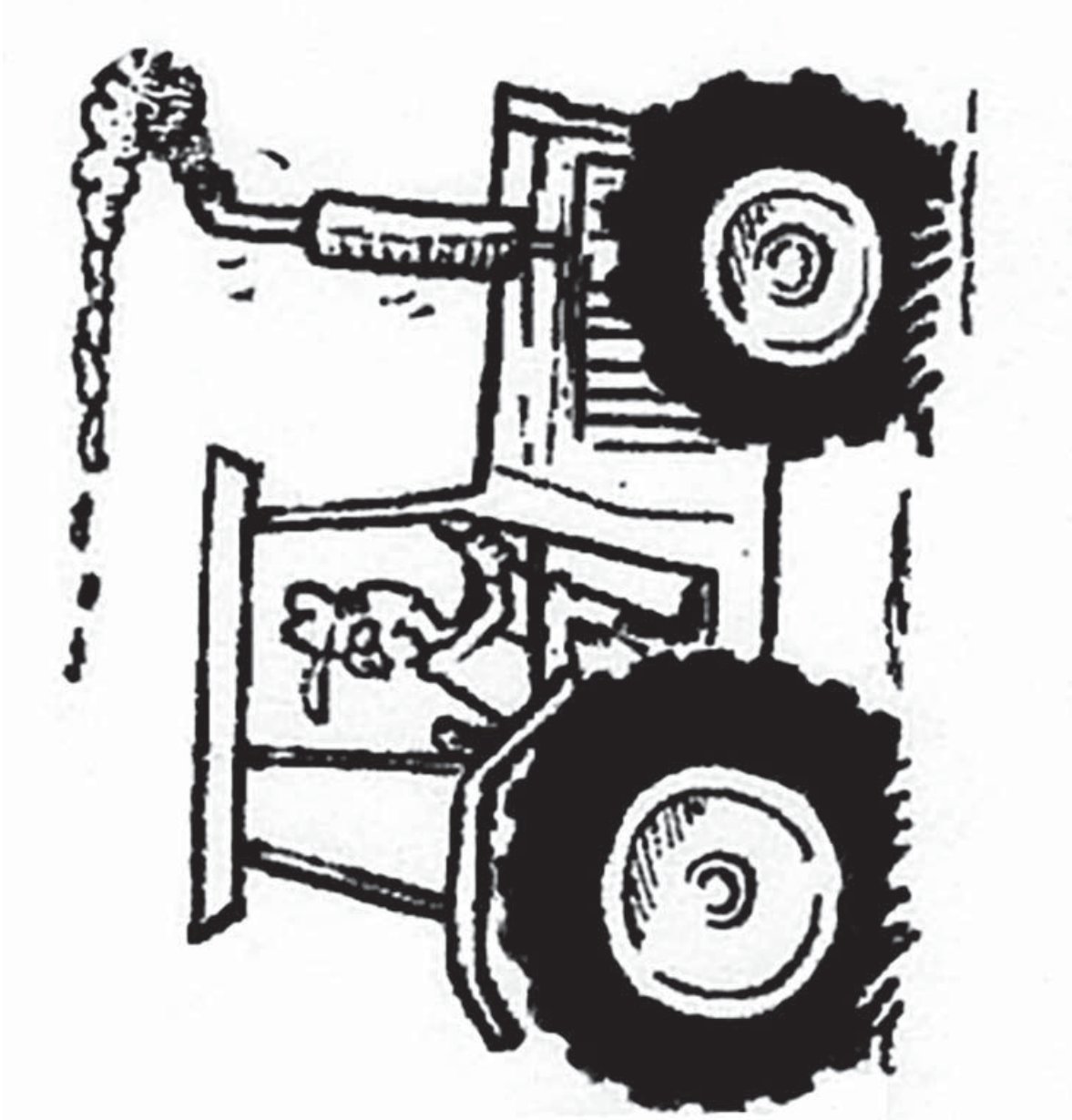

TRACTOR STABILITY (RESOURCES)

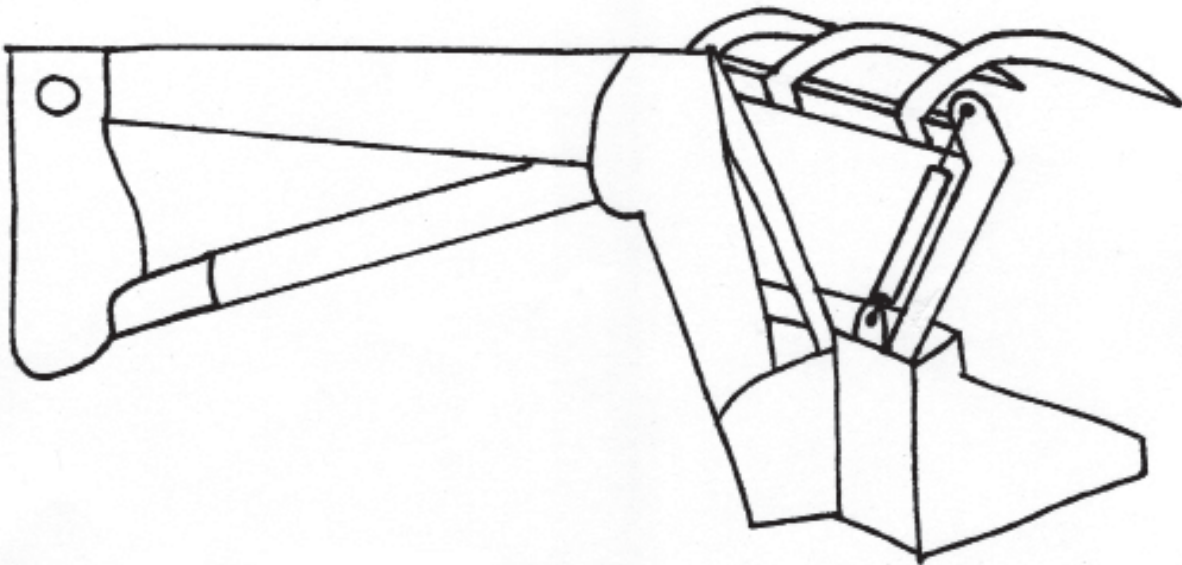
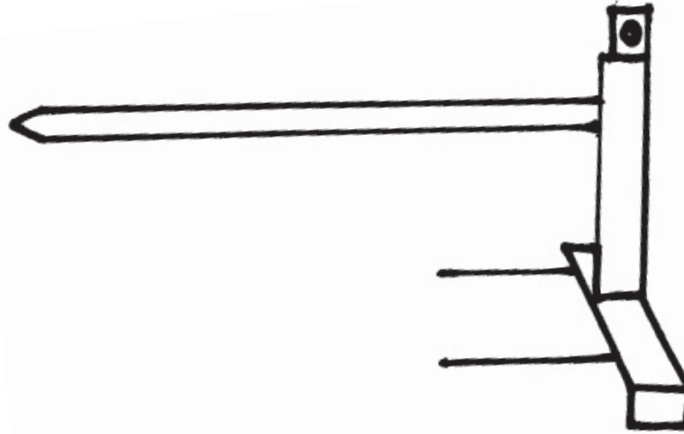

Puzzles

Crossword Puzzles	
No Extra Riders	Page 39
Rollover Protective Structure (ROPS)	Page 40
Falls	Page 41
Power Take-offs (PTOs)	Page 42
Rural Roadway Safety	Page 43
Sudoku Puzzles	
Puzzles 1 - 4	Page 44
Puzzles 5 - 7	Page 45
Tractor Bingo	Page 46
Square Eights	Page 47
Safe Operation	Page 48
Window Boxes	Page 50
From Start to Finish and Everything in Between	Page 51
Tractor Detective	Page 52
Coloring Pages	
A Safe Tractor Ride	Page 53
Safe Fun in the Rural Sun	Page 54
No Extra Seat, No Riders	Page 55
Keep It Safe	Page 56
Tractor Secret Safety Code	Page 57
Mechanical Hazards Match Up	Page 58
Answer Keys	
Crossword Puzzles	Page 59
Sudoku Puzzles	Page 60
Safe Operation	Page 61
Square Eights	Page 62
Window Boxes	Page 62
From Start to Finish and Everything in Between	Page 62
Tractor Safety Secret Code	Page 62
Mechanical Hazards Match-up	Page 62

NO EXTRA RIDERS

Targeted Age: Upper elementary school students and above

	1									2					
3									4					5	
						6									
				7											
8			9												
			10						11						
										12					
				13											

Across

3. Sign that can be affixed to warn people about the dangers of extra riders
4. Young person
7. What you should do if someone asks you to ride on a tractor
8. Tractor operator's line of sight
10. Responsible person; older than a child or youth
11. Tragic result of riding on a tractor
12. Safe response when offered a ride on a tractor
13. Sound that can hurt your ears

Down

1. Sense that can be damaged by exposure to high decibel noises
2. Shaking caused by tractor movement
5. Large, commonly used farm machine
6. Dirt in the air
9. Safe alternative mode of transportation; do this instead of riding on a tractor



ROLLOVER PROTECTIVE STRUCTURE (ROPS)

Targeted Age: Upper elementary school students and above

	1		2				3			4						5		
					6										7			
8																		
										9								
				10														
				11						12								
	13																	
14																		

Across

1. Metal implement hitch located on the back of a tractor
4. Sharp slope
6. Raised mound of earth
7. Backside of the tractor
8. Direction a tractor might tip if mowing a ditch
9. Wear a seatbelt on a ROPS tractor to protect you from being ___ in an overturn
10. Weighs a lot
11. Implement pulled behind a tractor; used for cutting
12. Large, commonly used farm machine
14. End of life

Down

2. Rod between two wheels
3. This can occur when a tractor becomes unbalanced
4. Resistance to tipping
5. Rate at which a vehicle is traveling
8. Steepness of a hill
13. Safety mechanism worn around waist to protect driver



FALLS

Targeted Age: Upper elementary school students and above

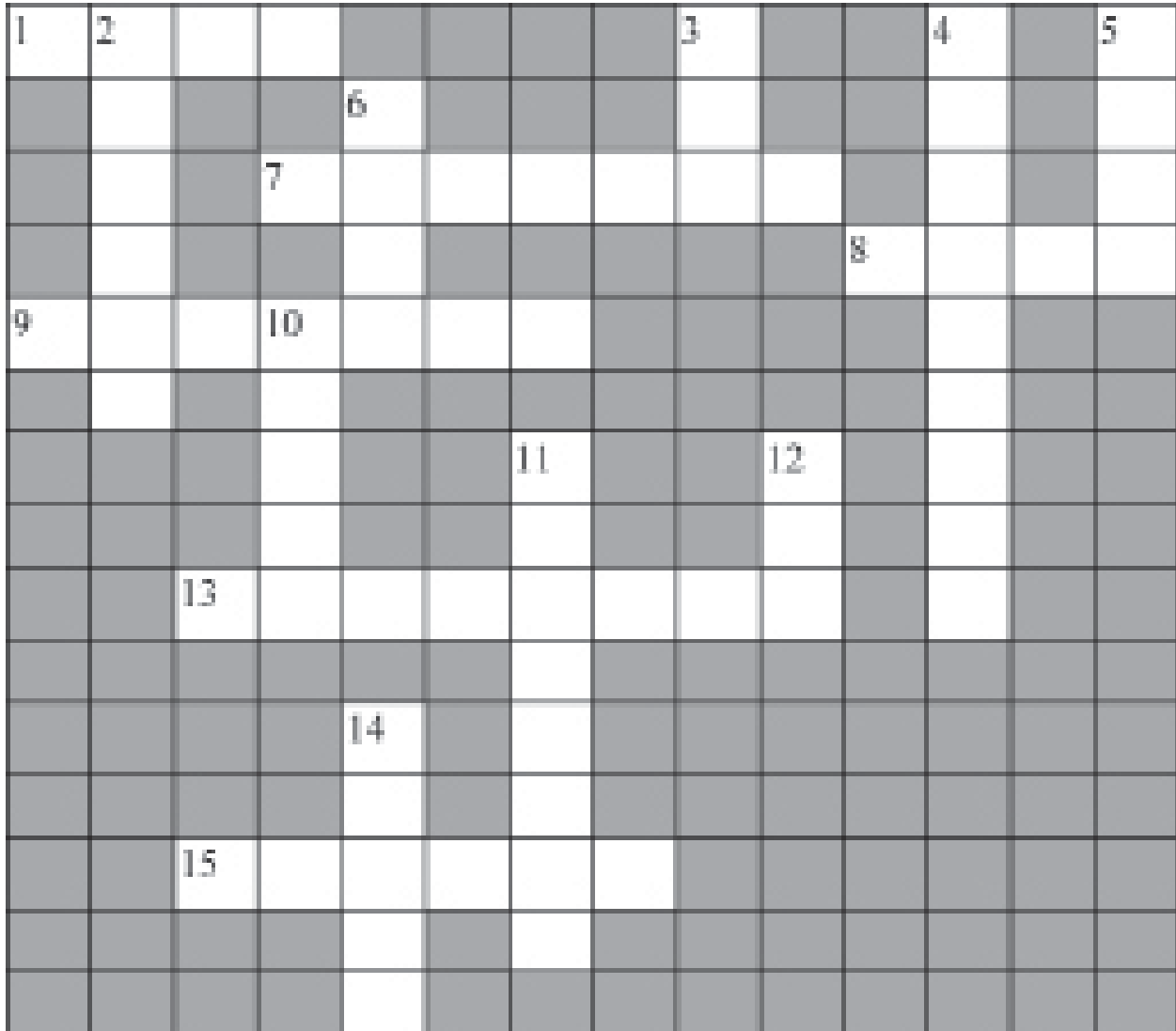

Across

- 1. Far from the ground
- 7. Support to hold on to
- 8. Lose your balance
- 9. Large, commonly used farm machine
- 13. Barrier that may impede tractor movement
- 15. Animal waste; slippery substance

Down

- 2. Harm the body
- 3. Always wear __-slip shoes when climbing onto a tractor
- 4. Mechanism pulled behind a tractor
- 5. Dangerous way to dismount a tractor
- 6. Not slow
- 10. Using a ladder to go up
- 11. High surface to stand on
- 12. Frozen water
- 14. Hard body parts that can be broken

POWER TAKE-OFFS (PTOS)

Targeted Age: Upper elementary school students and above

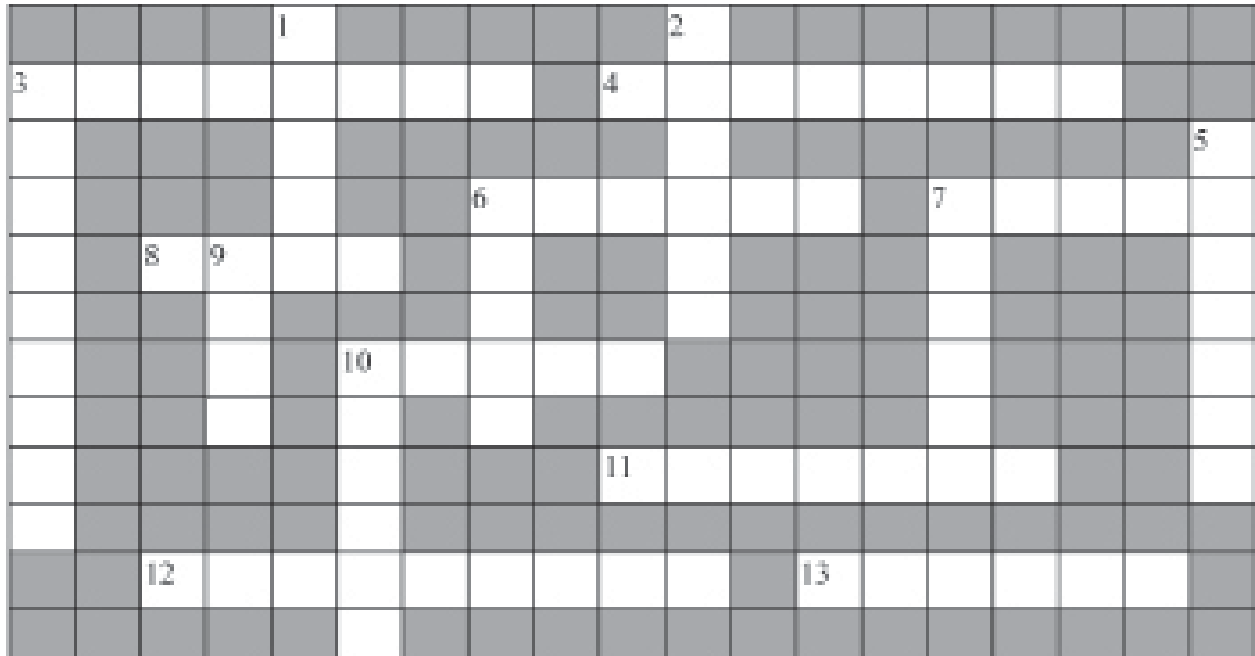

Across

3. Type of hair or jewelry that can become caught in a PTO
4. Become twisted
6. Walk ___ the tractor when the PTO is running
7. Implement used to cut grass
8. Never ___ over an operating PTO
10. PTOs rotate at a high ___
11. Result of getting hair caught in a PTO
12. Mechanism pulled behind a tractor
13. Spin around

Down

1. Wear ___ fitting clothing when working with a PTO
2. Wound
3. Shaft of a PTO
5. Large, commonly used farm machine
6. Corkscrew-like mechanism that moves grain
7. ___ spreader
9. How should long hair be worn to prevent it from getting caught in a PTO?
10. PTO shaft cover

RURAL ROADWAY SAFETY

Targeted Age: Upper elementary school students and above

	1		2						3			4			5		
6								7							8		
			9	10													
	11								12								
			13					14									
			15														

Across

- 2. Not going fast
- 6. Not slow
- 7. Curve in the road
- 8. Raised mound of earth
- 9. Small truck
- 11. Turn over
- 12. Passenger vehicle
- 13. Abbreviation for slow moving vehicle
- 14. Large, commonly used farm machine
- 15. Trench along the side of the road

Down

- 1. Opposite of small
- 2. Sharply sloped
- 3. Lane used to exit farmstead
- 4. Surface of many rural roads
- 5. Farm animals that might wander on to the road
- 10. Mechanism pulled behind a tractor



SUDOKU PUZZLES

Targeted Age: Upper elementary school students and above





To solve Sudoku puzzles, place a different letter or symbol in each row across, each column, and each small 9-box square. No letter or symbol may appear more than once in any row, column, or small 9-box square. Rearrange the letters in the shaded boxes to form a word associated with tractors.

#1 M S R A O T D C Z

Z		T			S		C	A
		C	M	T				S
D			Z		R		T	
		Z			O			R
		M	A	R	Z	T		
O			C			D		
	R				D			M
M				A	C	O		
A	Z		O			C		T





ANSWER: _____

#2 L T N R P A G U 

	L				P			U
				G	R			T
T	R					G		A
				L			N	P
	U						A	
L	P		R	A				
N		L			A		U	
R		G	N					
P			T				G	

ANSWER: _____

#3 I O S B V X P M 

M			O	S	P			
					X	M		P
	P	I						S
			P	O	I	V		
	X	P		M		B	O	
		V	X	B				I
B	I						P	
P		M						
			M	P	O			B

ANSWER: _____

#4 L E N T C I R A O

C		O	E			I	A	
				T				
E				A	L	C		N
R	A				E	N	O	
			N		R			
	O	T	I				L	R
A		N	L	I				C
				E				
	R	L			C	O		E

ANSWER: _____

SUDOKU PUZZLES

Targeted Age: Upper elementary school students and above

To solve Sudoku puzzles, place a different letter or symbol in each row across, each column, and each small 9-box square. No letter or symbol may appear more than once in any row, column, or small 9-box square. Rearrange the letters in the shaded boxes to form a word associated with tractors.

#5 C F R T M A O S ☒

			O	S			C	F
S	C	☒		A	T			
F					C			A
		M			S		T	
		C	☒	O	A	S		
	☒		T			R		
☒			A					R
			R	T		C	A	S
C	A			M	F			

ANSWER: _____

#6 F I R K Y G S O ☒

G		Y			F			K
I				☒				F
		K	I		R	☒	G	
	R	G		I			S	
				K				
	Y			F		K	O	
	F	I	S		Y	G		
Y				G				R
☒			K			Y		S

ANSWER: _____

#7 S O T R Y W E F A

		W				Y	S	
	F		O			T		
	S	T			A			F
	W	O	T				Y	R
T			A	R	S			O
E	A				Y	S	F	
W			E			F	O	
		E			F		T	
	T	Y				E		







ANSWER: _____



TRACTOR BINGO

Targeted Age: All ages

Make a photocopy for each participant. With a pencil in hand, find someone within the group that can answer each statement. Each person can only sign one space per page. The first person to get signatures on five boxes in a row wins!

Does not allow extra riders on the tractor	Turned 16 before driving a tractor on a public road	Knows how to turn off a PTO	Has ROPS on all tractors 	Uses a tractor with a cab more often than one without
Has been injured by a PTO 	Knows what SMV stands for	Knows what ROPS stands for	Exclusively drives red tractors	Exclusively drives yellow tractors
Drives several different colored tractors	Grandpa still drives a tractor	FREE SPACE	Rode on a tractor with an adult as a child	Wears ear plugs when operating loud machinery 
Has ridden in an antique tractor parade	Has driven a tractor in a parade 	Received an antique tractor calendar for a present	Ties hair back before working around machinery 	Taught a tractor safety class
Overtaken a tractor and survived	Knows the hand signal for "shut off"	Knows someone who was injured in a tractor incident	Owens an AGCO hat 	Has a toy tractor collection

Supplemental Activity: Identify which statements are unsafe. Why are they unsafe? Ask them to give additional information about the experience, situation, or item described in each statement. How does each answer influence the safety of the individual involved? Which items do not impact safety?

SQUARE EIGHTS

Targeted Age: Elementary school students

Find the tractor related, eight-letter-word in each square. Words can be spelled forwards or backwards and can start in any box. Match the word with the correct definition.

- A. Get down off the tractor
- B. When a tractor turns over on itself
- C. Cooling device
- D. Large, commonly used farm machines
- E. Opposite of upwards
- F. Round tube
- G. Electrical system that starts the engine
- H. A state of mind
- I. Fuel for combustible engine
- J. Electrical lines that should be avoided when using a front end loader
- K. Covered PTO shaft

T	S	R
R		O
A	C	T

1. Word _____
Definition match ____

I	G	N
N		I
O	I	T

2. Word _____
Definition match ____

U	D	E
T		A
I	T	T

3. Word _____
Definition match ____

T	R	E
U		V
R	N	O

4. Word _____
Definition match ____

I	L	O
N		S
E	G	A

5. Word _____
Definition match ____

L	Y	C
I		R
N	D	E

6. Word _____
Definition match ____

R	D	D
A		O
W	N	W

7. Word _____
Definition match ____

T	O	R
A		R
I	D	A

8. Word _____
Definition match ____

D	I	S
T		M
N	U	O

9. Word _____
Definition match ____

O	V	E
D		R
A	E	H

10. Word _____
Definition match ____

D	L	E
E		I
D	S	H

11. Word _____
Definition match ____

Supplemental Activity:
Each word relates to operating a tractor safely. After you unscramble the words, try using them in a sentence.

SAFE OPERATION

Targeted Age: Middle school students

Each box contains a message about staying safe around tractors. Decode the message by drawing one continuous line, reading the words in any direction, horizontally, vertically and/or diagonally. Each letter is only used once. Start at the circled letter and end at the shaded square. Hint: Your lines will never cross.

EXAMPLE

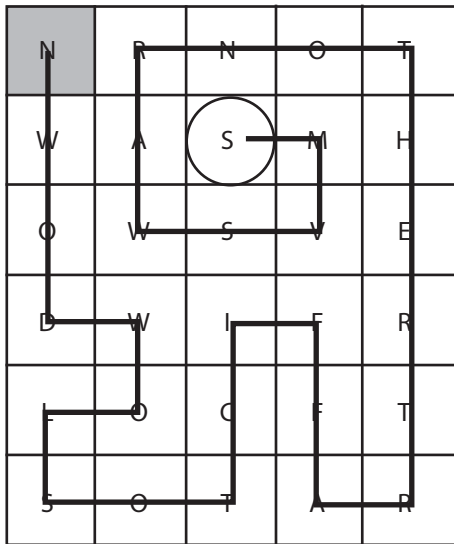

Hint: Reflective triangles help drivers see tractors while on the road.

Answer: SMVs warn other traffic to slow down

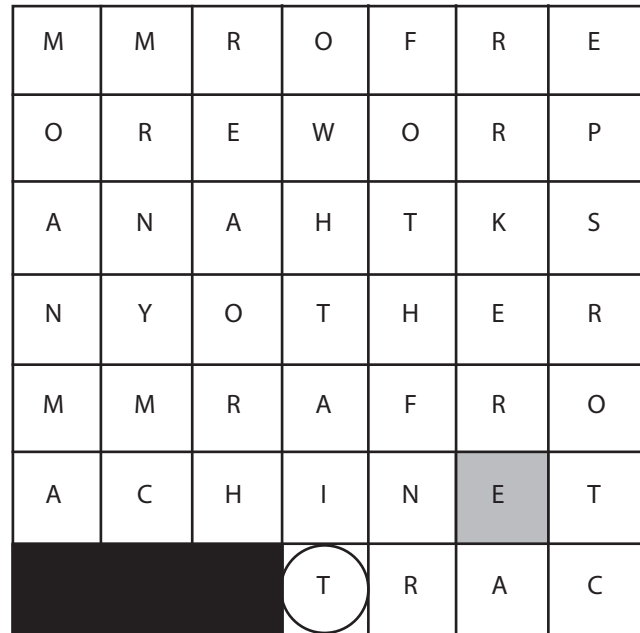

Hint: This large piece of equipment is on almost every farm.

Supplemental Activity: Each statement listed above talks about the safe use of tractors on the farm. Have each student write an additional statement, and using graph paper, create their own puzzle for another person to solve.

SAFE OPERATION

Targeted Age: Middle school students

Each box contains a message about staying safe around tractors. Decode the message by drawing one continuous line, reading the words in any direction, horizontally, vertically and/or diagonally. Each letter is only used once. Start at the circled letter and end at the shaded square. Hint: Your lines will never cross.

N	G	I	S	E	D
E			A	R	E
D	F	T	S		
R	O	R	R	R	E
W	O	A	O	N	G
K	R	C	T	E	S
N	O	T	P	A	S

Hint: Dangerous place to be on a tractor.

T	C	U	R	T	T	C
U	R	E	S	S	I	E
T	O	R	P	E	V	T
E	C	R	O	L	L	O
T	T	V	I	R	O	R
R		R	E	D	V	P
A	C	T	O	R	E	R

Hint: This device helps protect a tractor operator.

L	L	P	O	P	I
	A	R	T	S	L
T	F	E	S	H	S
N	E	V	E	O	N
W	E	A	R	N	O

Hint: Type of footwear to use while on a tractor.



WINDOW BOXES

Targeted Age: Middle school students

There are tractor-related, 4-letter words hidden amongst the letters in Column 1. Each word shows the letters in the correct order but other letters have been added. Find the hidden word then draw a line to match the word to the blank boxes in the second column.

EXAMPLE

O	B	D	U	R	M	E	P
F	A	R	M	I	N	G	S

X

F	A	R	M				
	B		U		M		P

Column 1

1.

W	E	L	L	O	R	D	K
---	---	---	---	---	---	---	---
2.

I	F	O	R	K	A	L	L
---	---	---	---	---	---	---	---
3.

H	I	S	E	A	D	T	O
---	---	---	---	---	---	---	---
4.

O	W	A	T	E	R	R	N
---	---	---	---	---	---	---	---
5.

I	C	S	O	F	L	I	P
---	---	---	---	---	---	---	---
6.

S	E	T	T	L	O	W	N
---	---	---	---	---	---	---	---
7.

T	A	K	U	R	D	X	N
---	---	---	---	---	---	---	---
8.

O	B	S	U	T	E	R	P
---	---	---	---	---	---	---	---
9.

R	E	A	O	P	E	S	H
---	---	---	---	---	---	---	---
10.

Q	U	I	B	E	C	L	T
---	---	---	---	---	---	---	---

Column 2

- A.

--	--	--	--	--	--	--	--
- B.

--	--	--	--	--	--	--	--
- C.

--	--	--	--	--	--	--	--
- D.

--	--	--	--	--	--	--	--
- E.

--	--	--	--	--	--	--	--
- F.

--	--	--	--	--	--	--	--
- G.

--	--	--	--	--	--	--	--
- H.

--	--	--	--	--	--	--	--
- I.

--	--	--	--	--	--	--	--
- J.

--	--	--	--	--	--	--	--

Supplemental Activity: Each of the words listed in the boxes are related to using a tractor. After participants identify the words, conduct a group activity by having each child use the words correctly in a sentence to show he or she knows the meaning of the words. See who can form a complete sentence using the most words from the puzzle. Example: Slip-resistant shoes should be worn to prevent falls on stairs. ROPS and seat belts can prevent injuries.

FROM START TO FINISH AND EVERYTHING IN BETWEEN

Targeted Age: Middle school students

Start with the three words CARRY NO PASSENGERS and follow the directions to complete the thought.

CARRY NO PASSENGERS

Remove the first letter of the last word

Remove all double letters

Substitute 's' for 'c'

Add 'rid' in front of the second 'a'

Duplicate the 5th letter

Add a space and 't' between the double letters

Remove the 2 vowels right together

Remove 'ng'



Supplemental Activity: Identify two short phrases that are related to tractor safety and each other, for example: "A rollover protective structure" and "Could save a life." Write instructions to change the letters in the first phrase to end up with the letters and spacing for the second phrase. See who can change the phrase in the least number of steps.

TRACTOR DETECTIVE

Targeted Age: Early elementary school students

Tractors are used to complete farm work, pull, and power implements. They are not designed for transportation. Find the item in this picture that shows a safe way to get from one place to another.

Here's how to find out:

- ▶ Draw a line between two words that rhyme.
- ▶ Draw line between the tractors.
- ▶ Draw a line between the two letters that rhyme.

The lines cross at the picture representing a safe mode of transportation.

H

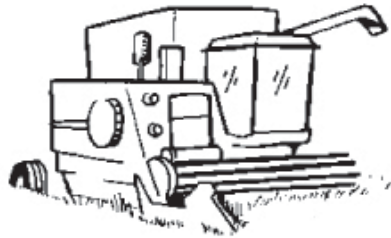

HEAT

M



SLOW

D

CAB

ROPS

TRACTOR



GO

L

B

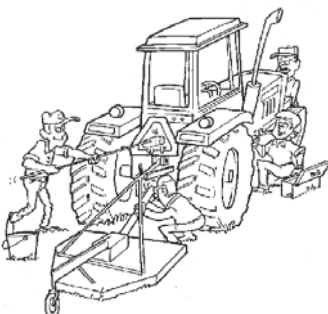

SEAT

A



SMV

A Safe Tractor Ride



Safe Fun in the Rural Sun



No Extra Seat

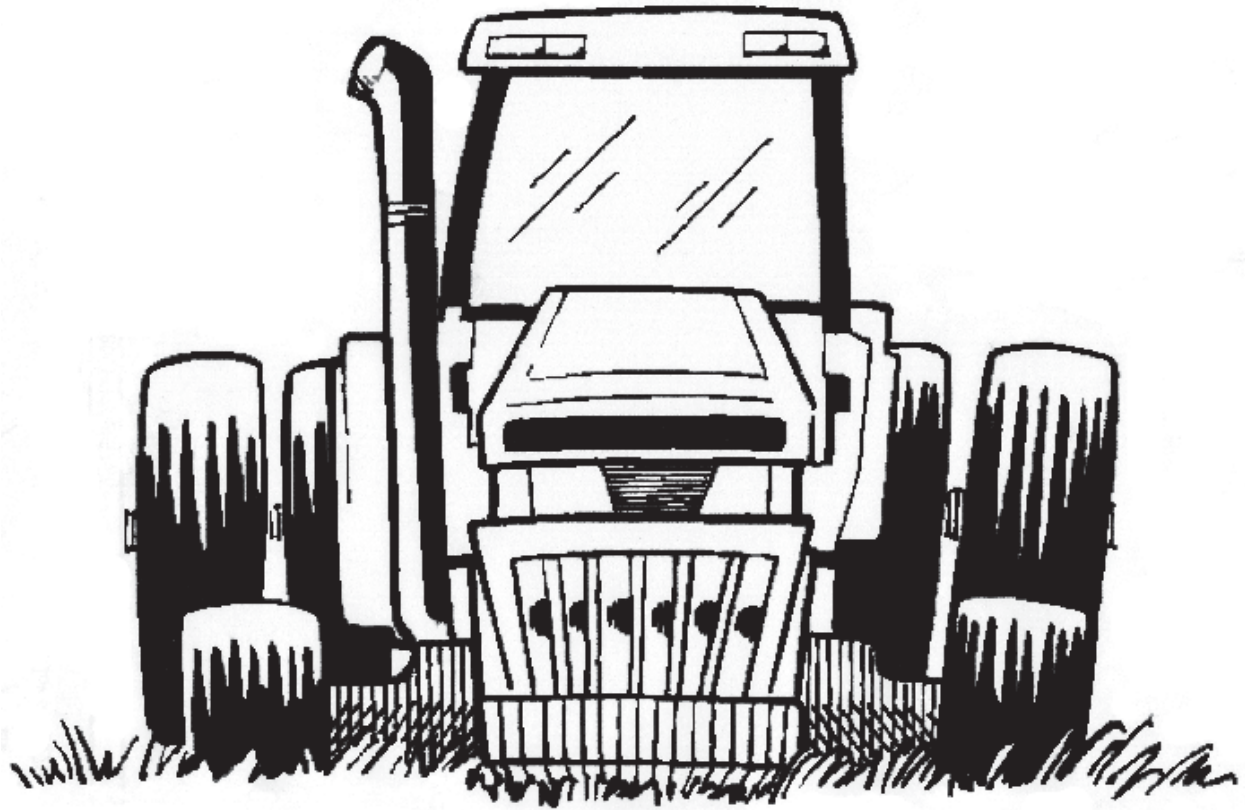

No Riders!

Keep it Safe

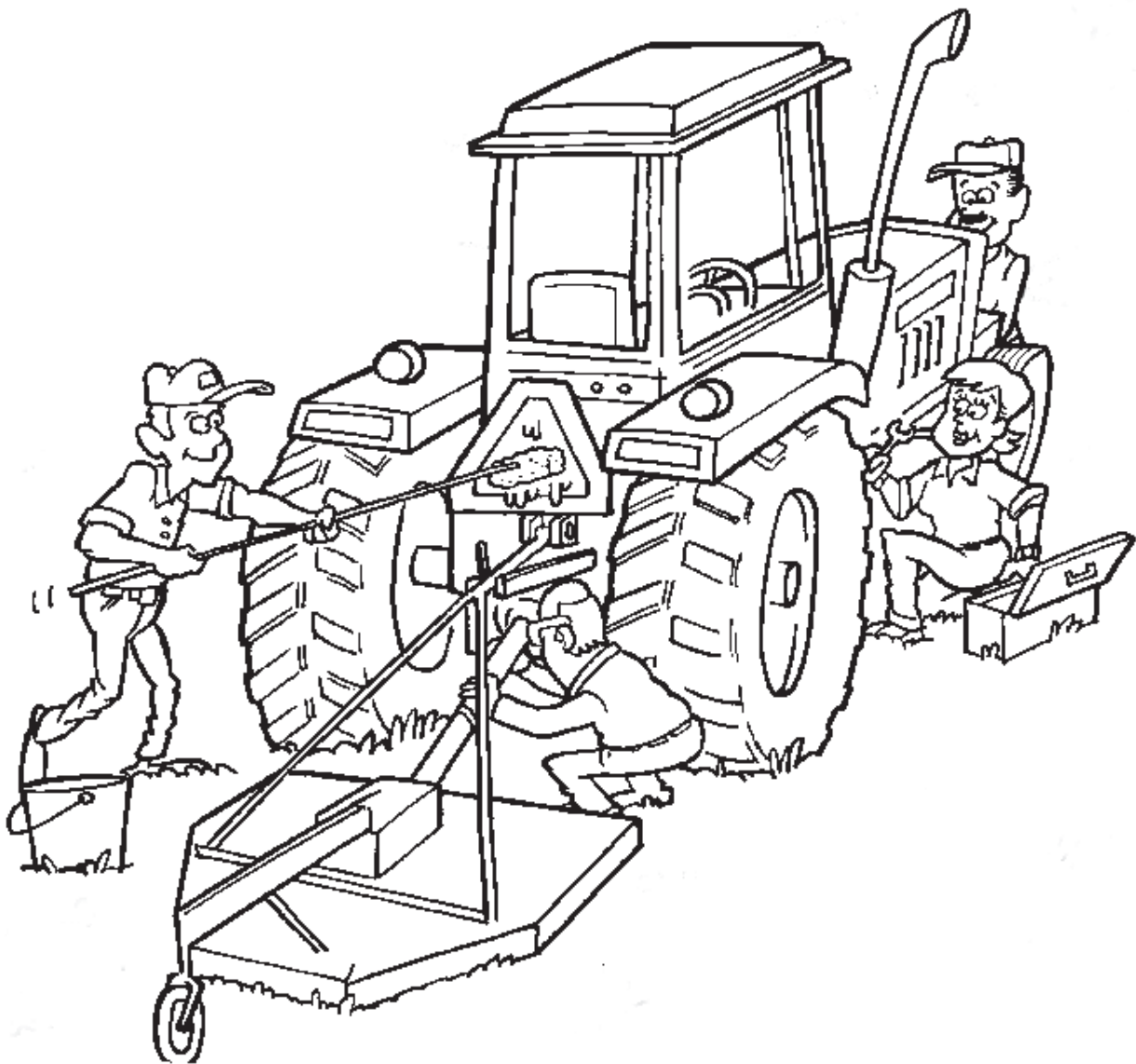

TRACTOR SECRET SAFETY CODE

Targeted Age: Upper elementary school students

Decode the secret messages to find out how to stay safe while around tractors.

A = ✓	E = 📦	I = ⓘ	M = ⚠	Q = ⌛	U = 🚰	Y = ⊖
B = 🚲	F = 🚗	J = ✈	N = ●	R = ✕	V = 🚝	Z = ⓧ
C = □	G = ■	K = 🌿	O = 🌅	S = ?	W = 🏹	
D = 🛡	H = 🚚	L = ✨	P = 🚗	T = 🏠	X = ⓧ	

EXAMPLE

✕ 🌅 🚗 ? ? ✓ 🚗 📦 ✨ ⓘ 🚗 📦 ?
 R O P S S A V E L I V E S

📦 ⓧ 🏠 ✕ ✓ ✕ ⓘ 🛡 📦 ✕ ? 🌅 ●
 _ _ _ _ _ _ _ _ _ _

🏠 ✕ ✓ □ 🏠 🌅 ✕ ? 🚗 🚰 🏠 🚲 🌅 🏠 🚚
 _ _ _ _ _ _ _ _ _ _

🏠 🚚 📦 ✕ ⓘ 🛡 📦 ✕ ✓ ● 🛡 🛡 ✕ ⓘ 🚗 📦 ✕
 _ _ _ _ _ _ _ _ _ _

✓ 🏠 ✕ ⓘ ? 🌿 .
 _ _ _ _ _

Supplemental Activity: Write your own statement about safe tractor use.
 Example: Extra riders on tractors are at risk of health problems such as dust in the lungs, vibration to body organs, and excessive noise.

MECHANICAL HAZARDS MATCH UP

Targeted Age: Middle school students

Match the tractor dangers to the appropriate hazard point.



Answer:

Tractor Danger:

Hazard Point:

- | | | |
|-------|---|------------------|
| _____ | 1. An unshielded auger drags a person's arm into the mechanism. | A. Pinch point |
| _____ | 2. While hitching a wagon onto the back of the tractor, a finger gets caught between the two pieces of the drawbar. | B. Wrap point |
| _____ | 3. Someone steps over a Power Take-Off (PTO) and their pants get caught in the rotating shaft. | C. Shear point |
| _____ | 4. The hydraulic hose connection comes loose and hits a person in the face. | D. Crush point |
| _____ | 5. The fan blade shield has been removed and a rock is projected towards a person. | E. Burn point |
| _____ | 6. A chain belt drive is exposed where a finger could get caught. | F. Pull-in point |
| _____ | 7. The front end loader falls on a person standing underneath. | G. Stored energy |
| _____ | 8. Bumping up against a hot muffler. | H. Thrown object |

Instructor note: See page 8 in the Tractor Safety packet's background information section for help completing this activity.

ANSWER KEY

Crossword Puzzles

No Extra Riders

Across

3. Decal
4. Child
7. Refuse
8. View
10. Adult
11. Fatality
12. No
13. Noise

Down

1. Hearing
2. Vibration
5. Tractor
6. Dust
9. Walk

Rollover Protective Structure (ROPS)

Across

1. Drawbar
4. Steep
6. Hill
7. Rear
8. Side
9. Injured
10. Heavy
11. Mower
12. Tractor
14. Death

Down

2. Axle
3. Rollover
4. Stability
5. Speed
8. Slope
13. Seatbelt

Falls

Across

1. High
7. Railing
8. Slip
9. Tractor
13. Obstacle
15. Manure

Down

2. Injure
3. Non
4. Implement
5. Jump
6. Fast
10. Climb
11. Platform
12. Ice
14. Bones

Power Take-offs (PTOs)

Across

3. Dangling
4. Entangle
6. Around
7. Mower
8. Step
10. Speed
11. Scalped
12. Implement
13. Rotate

Down

1. Close
2. Injury
3. Driveline
5. Tractor
6. Auger
7. Manure
9. Tied
10. Shield

Rural Roadway Safety

Across

2. Slow
6. Fast
7. Corner
8. Hill
9. Pickup
11. Flip
12. Car
13. SMV
14. Tractor
15. Ditch

Down

1. Large
2. Steep
3. Driveway
4. Gravel
5. Livestock
10. Implement

ANSWER KEY

Sudoku Puzzles

#1 TRACTOR

Z	M	T	D	O	S	R	C	A
R	O	C	M	T	A	Z	D	S
D	S	A	Z	C	R	M	T	O
T	C	Z	S	D	O	A	M	R
S	D	M	A	R	Z	T	O	C
O	A	R	C	M	T	D	S	Z
C	R	O	T	Z	D	S	A	M
M	T	S	R	A	C	O	Z	D
A	Z	D	O	S	M	C	R	T

#2 PULL

G	L		A	T	P	N	R	U
U	N	A	L	G	R		P	T
T	R	P		U	N	G	L	A
A	G	R	U	L		T	N	P
	U	T	P	N	G	L	A	R
L	P	N	R	A	T	U		G
N	T	L	G	P	A	R	U	
R	A	G	N		U	P	T	L
P		U	T	R	L	A	G	N

#3 SMV

M	B		O	S	P	I	X	V
O	V	S	I		X	M	B	P
X	P	I	B	V	M	O		S
	M	B	P	O	I	V	S	X
I	X	P	S	M	V	B	O	
S	O	V	X	B		P	M	I
B	I	O	V	X	S		P	M
P	S	M		I	B	X	V	O
V		X	M	P	O	S	I	B

#4 TRACTION

C	T	O	E	R	N	I	A	L
L	N	A	C	T	I	R	E	O
E	I	R	O	A	L	C	T	N
R	A	C	T	L	E	N	O	I
I	L	E	N	O	R	A	C	T
N	O	T	I	C	A	E	L	R
A	E	N	L	I	O	T	R	C
O	C	I	R	E	T	L	N	A
T	R	L	A	N	C	O	I	E

#5 FARM

T	M	A	O	S	R		C	F
S	C		F	A	T	M	R	O
F	R	O	M		C	T	S	A
O	F	M	C	R	S	A	T	
R	T	C		O	A	S	F	M
A		S	T	F	M	R	O	C
	S	T	A	C	O	F	M	R
M	O	F	R	T		C	A	S
C	A	R	S	M	F	O		T

#6 RISK

G		Y	O	S	F	I	R	K
I	O	R	G		K	S	Y	F
F	S	K	I	Y	R		G	O
K	R	G		I	O	F	S	Y
O	I	F	Y	K	S	R		G
S	Y		R	F	G	K	O	I
R	F	I	S	O	Y	G	K	
Y	K	S	F	G		O	I	R
	G	O	K	R	I	Y	F	S

#7 SAFETY

O	E	W	F	T	R	Y	S	A
Y	F	A	O	S	W	T	R	E
R	S	T	Y	E	A	O	W	F
S	W	O	T	F	E	A	Y	R
T	Y	F	A	R	S	W	E	O
E	A	R	W	O	Y	S	F	T
W	R	S	E	A	T	F	O	Y
A	O	E	S	Y	F	R	T	W
F	T	Y	R	W	O	E	A	S

ANSWER KEY

Safe Operation

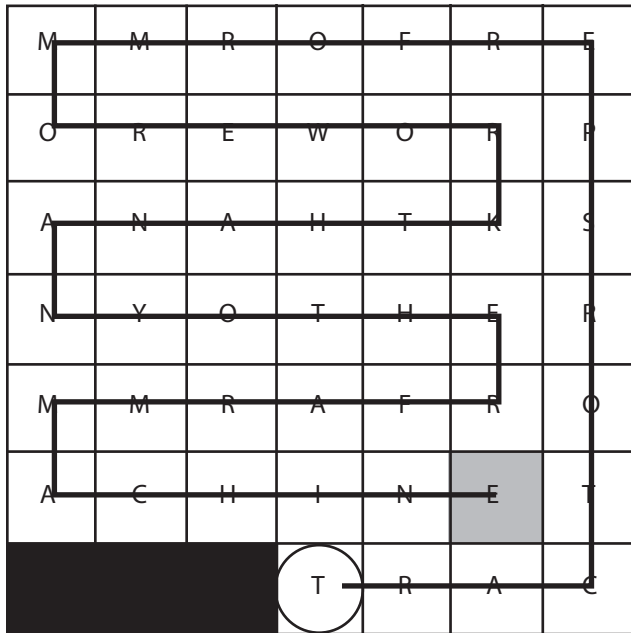

Tractors perform more work than any other farm machine

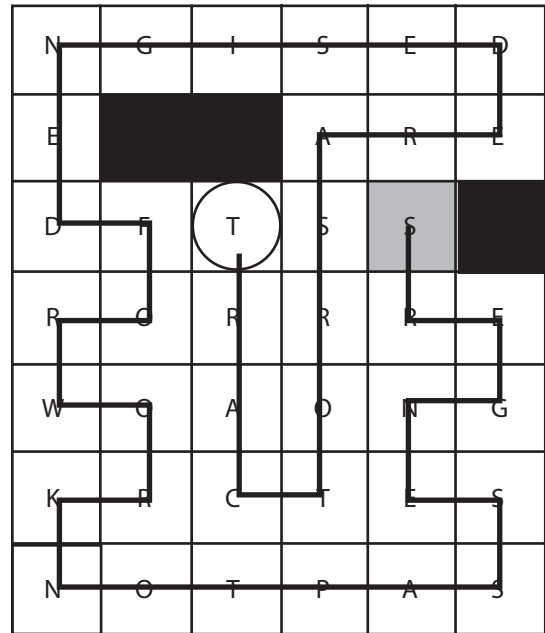

Tractors are designed for work not passengers

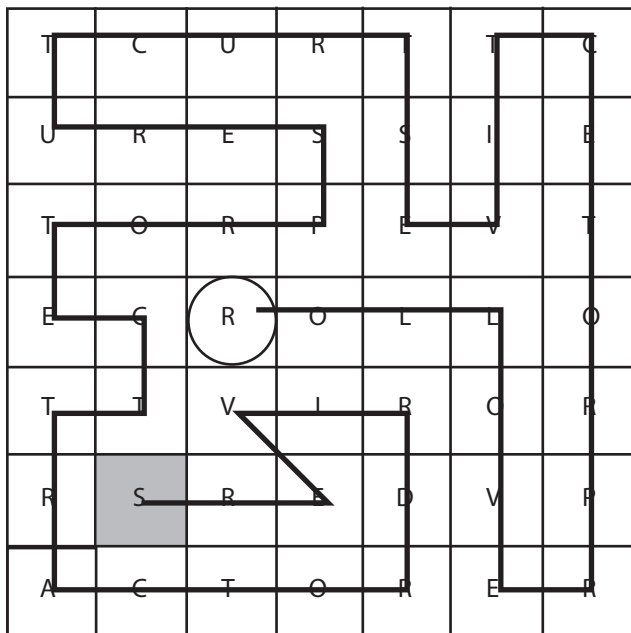

Rollover protective structures protect tractor drivers

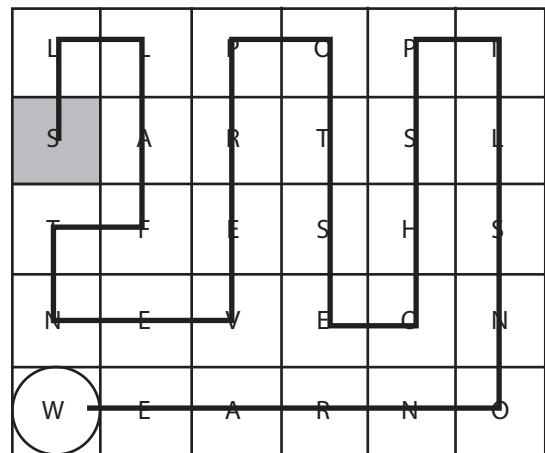

Wear nonslip shoes to prevent falls

ANSWER KEY
Square Eights

- | | |
|--------------------|------------------|
| 1. D - Tractors | 7. E - Downward |
| 2. G - Ignition | 8. C - Radiator |
| 3. H - Attitude | 9. A - Dismount |
| 4. B - Overturn | 10. J - Overhead |
| 5. I - Gasoline | 11. K - Shielded |
| 6. F - Cylindrical | |

Window Boxes

- | | |
|-------------|--------------|
| 1. H - Work | 6. E - Slow |
| 2. A - Fall | 7. J - Turn |
| 3. F - Seat | 8. G - Step |
| 4. B - Warn | 9. I - ROPs |
| 5. D - Slip | 10. C - Belt |

From Start to Finish and Everything in Between

Say no to riders

Tractor Secret Safety Code

Extra riders on tractors put both the rider and driver at risk

Mechanical Hazards Match Up

- | | |
|----------------------|----------------------|
| 1. F - Pull-in point | 5. H - Thrown object |
| 2. C - Shear point | 6. A - Pinch point |
| 3. B - Wrap point | 7. D - Crush point |
| 4. G - Stored energy | 8. E - Burn point |