



# **Tractors, the #1 Cause of Fatalities on the Farm<sup>1</sup>**

---

New York Center for Agricultural Medicine and Health<sup>2</sup>

## **OBJECTIVE**

1. Using a 5-point check list, the students will identify high-risk areas associated with farm tractors.
2. Students will be able to name five areas of a tractor to check for safety of operation, and be able to tell if they are safe or not.

## **BACKGROUND**

Farming is now the most dangerous occupation in the United States. Over half of reported farm fatalities are directly related to the tractor. Each year it is estimated that over 300 children are killed on farms. There are two main aspects of tractor safety; one is the equipment on the tractor, the other is the way it is operated. This lesson focuses on the equipment. The farm environment is very healthy and enjoyable, however more education is needed to protect those who have chosen this lifestyle.

## **MATERIALS**

1. Tractor safety checklist
2. A tractor, or pertinent parts, or pictures of them.

## **METHODOLOGY**

1. Review equipment terms on tractor checklist to ensure comprehension of task
2. In groups of 2 or 3, students will complete tractor checklist on an available tractor  
or
  - a. If no tractor is available, use parts or pictures to discuss each category so students can take the checklist home and perform the evaluation.
3. Review the five point checklist to reinforce actual safety features and their purpose.
4. The sound level meter is used to measure the decibels or loudness at the site of exposure with the various available farm equipment. For example, a tractor at both idle and full throttle, a lawn mower or a chain saw.

---

1. This training curriculum was produced by the New York Center for Agricultural Medicine and Health (NYCAMH).  
2. New York Center for Agricultural Medicine and Health, One Atwell Road, Cooperstown, New York 13326. Phone number: (607) 547-6023 or 1-800-343-7527 in the Northeast.

## EVALUATION

- Encourage students to take extra tractor checklist forms home and apply them to their own farm tractors, and report deficiencies they find.
- Reuse the checklist in 6 months to assess changes that have been made as a result of this lesson.

## EXTENSIONS

- Apply checklist to family farm equipment or whenever dealing with ag equipment
- Have students create a worksheet for other hazardous farm related activities, for example: power take-off equipment, feeding equipment, lawn mowers, chain saws, etc.

## VOCABULARY

**Slow Moving Vehicle (SMV)** - Is a reflective triangular sign required by law for (farm) vehicles using public highways moving at less than 25 miles per hour. (Must be mounted behind the seat, point up, 2 to 6 feet above the ground, near the center of the vehicle)

**Power Take-Off (PTO)** - a shaft that spins to transfer power from the tractor to the implement behind it. It rotates at a very high speed (540 or 1000 rotations per minute)

**Master Shield** - The three sided guard that is positioned around the PTO stub shaft where it protrudes from the back of the tractor.

**Roll-Over Protective Structure (ROPS)** - A tractor feature like a roll bar, designed to guard the operator from being crushed in the event of a turnover, safety tested and labelled by OSHA standards. Only effective when used with a seatbelt.

## RESOURCES

Student pages  
Checklist  
Vocabulary terms  
Miscellaneous handouts

## Tractor Safety Checklist

Put a check mark next to the box that correctly identifies your findings. A separate form should be used for each tractor.

### MUFFLER

	Like new
	Some wear and rust
	Mostly rusted and has holes
	Straight pipe or no muffler

### SLOW-MOVING VEHICLE (SMV) SIGN

	Bright orange and red colors
	Dull colors
	No SMV sign or missing

### MASTER SHIELD AROUND POWER TAKE-OFF (PTO) STUB

	All three sides of shield present
	Bent shield or in bad working condition
	No shield or missing

### ROLLOVER PROTECTION STRUCTURE (ROPS)

	Fully enclose cab with approved safety standard label
	2 or 4 Post ROPS with approved safety standard label
	Door or window missing in full cab
	No ROPS or a homemade ROPS

### SEAT BELT

	Has a seat belt and is used by the operator
	Has a seat belt but is <b>seldom</b> used by the operator
	Has a seat belt but <b>broken</b>
	No ROPS - seat belt should not be used

## Vocabulary Terms

- Slow Moving Vehicle (SMV) emblem -** Is a reflective sign required by law for (farm) vehicles using public highways moving at less than 25 miles per hour. (Must be mounted behind seat, point up, 2 to 6 feet above the ground, near the center of the vehicle).
- Power Take-Off (PTO) -** A shaft that spins to transfer power from the tractor to the implement behind it. It rotates at a very high speed (540 to 1000 revolutions per minute).
- Master Shield -** The three sided guard that is positioned around the PTO stub shaft where it protrudes from the back of the tractor.
- Roll-Over Protective Structure (ROPS) -** A tractor feature like a roll bar, designed to guard the operator from being crushed in the event of a turnover, safety tested and labelled by OSHA standards. Only effective when used with a seatbelt.

## Tractor fatality rates on the farm

Overturns have the highest fatality rate for unintentional tractor injuries occurring on the farm, according to reports from 29 states covering more than 66 percent of the tractors in U.S. In 1993, overturns accounted for 55 percent of all on-the-farm tractor fatalities reported, with a an annual rate of 4.1 deaths per 100,000 tractors.

For all tractor fatalities combined, projecting the overall rate of 7.5 deaths per 100,000 tractors in this sample to the nation's approximately 4.62 million tractors yields an estimated 351 tractor-related deaths on farms nationwide in 1993.

<b>Tractor fatalities on the farm by type of accident, 1980 - 1993</b>				
<b>Year</b>	<b>Percent of deaths</b>			
	<b>Overturns</b>	<b>Runovers</b>	<b>Power Takeoffs</b>	<b>Other</b>
1980	48	29	8	15
1981	58	20	7	15
1982	49	20	4	27
1983	58	22	1	19
1984	52	29	2	17
1985	51	26	7	16
1986	44	23	6	27
1987	52	24	3	21
1988	44	29	7	20
1989	55	15	2	28
1990	52	33	3	12
1991	47	30	4	19
1992	53	25	3	19
1993	55	23	4	18

Source: Deaths based on vital statistics and individual case reports by state agricultural safety specialists; tractors based on U.S. Census of Agriculture, 1987, estimated for 1990 by *Implement & Tractor*. Abstracted from the National Safety Council's 1994 edition of *Accident Facts*.

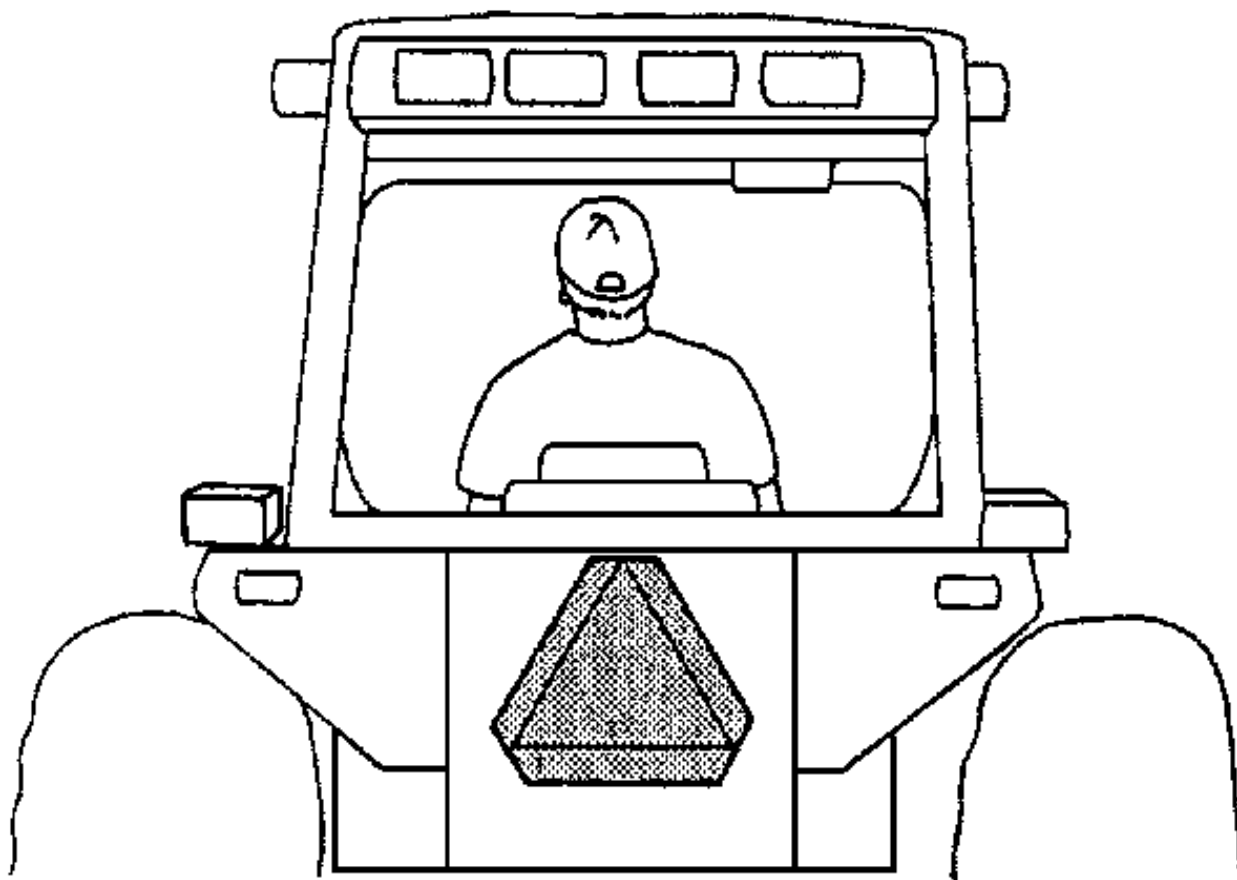

# POINT AT TOP

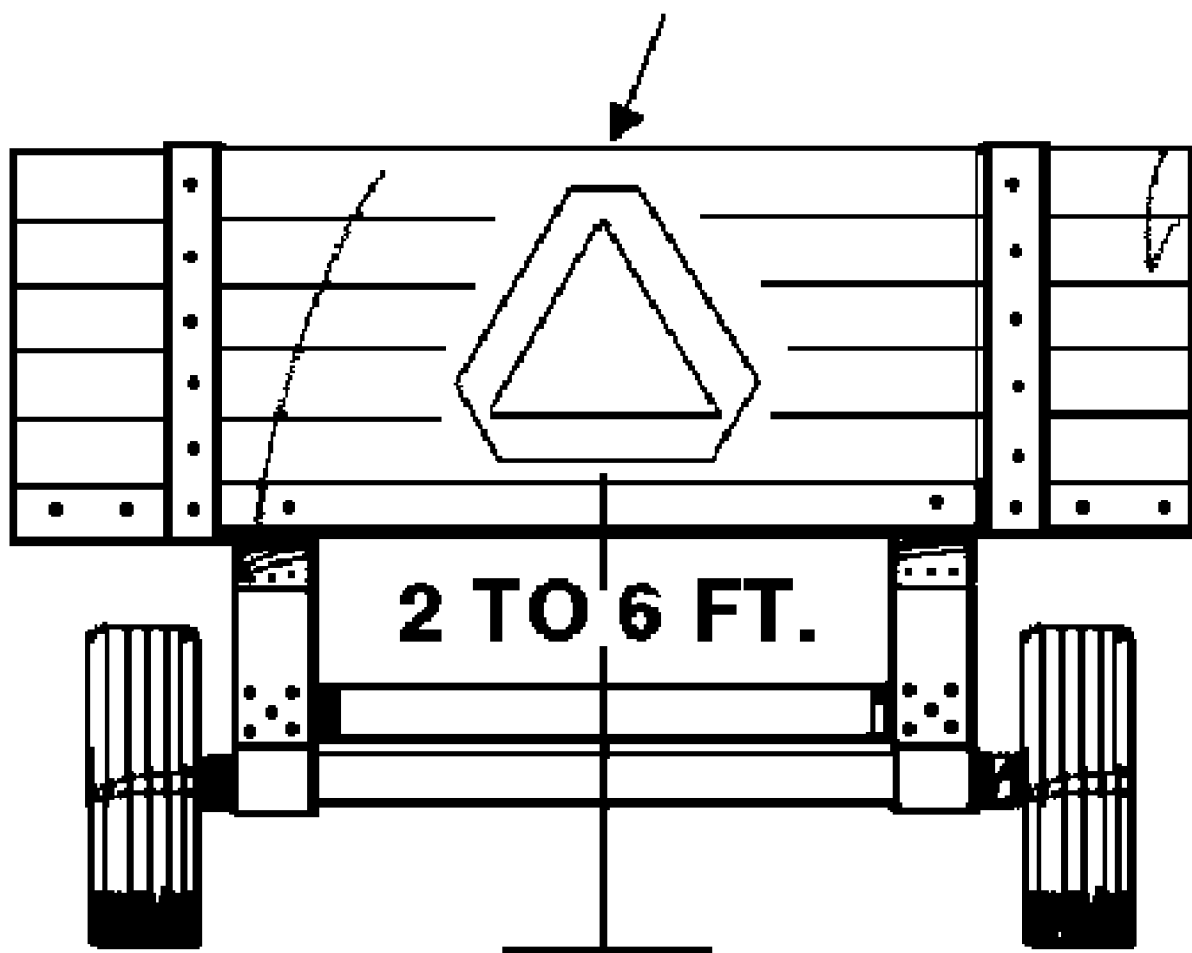

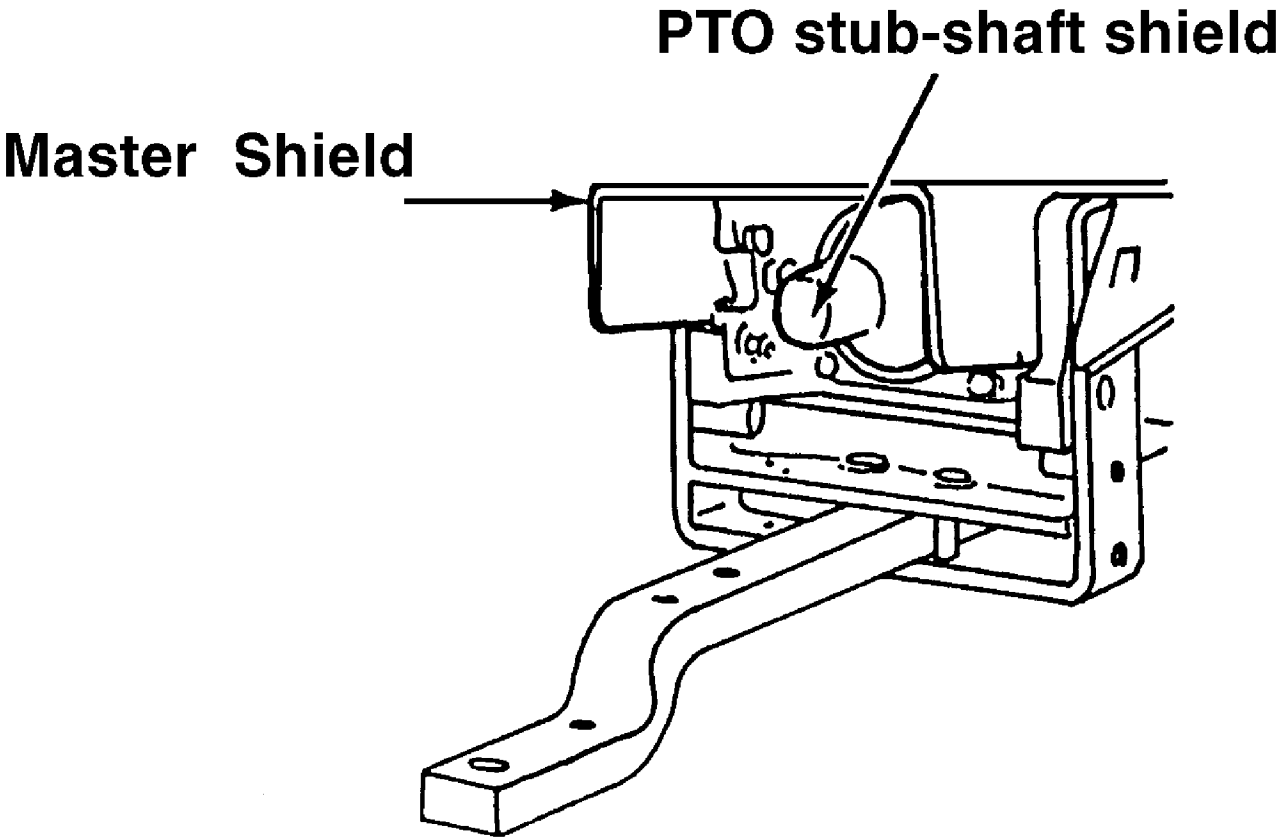



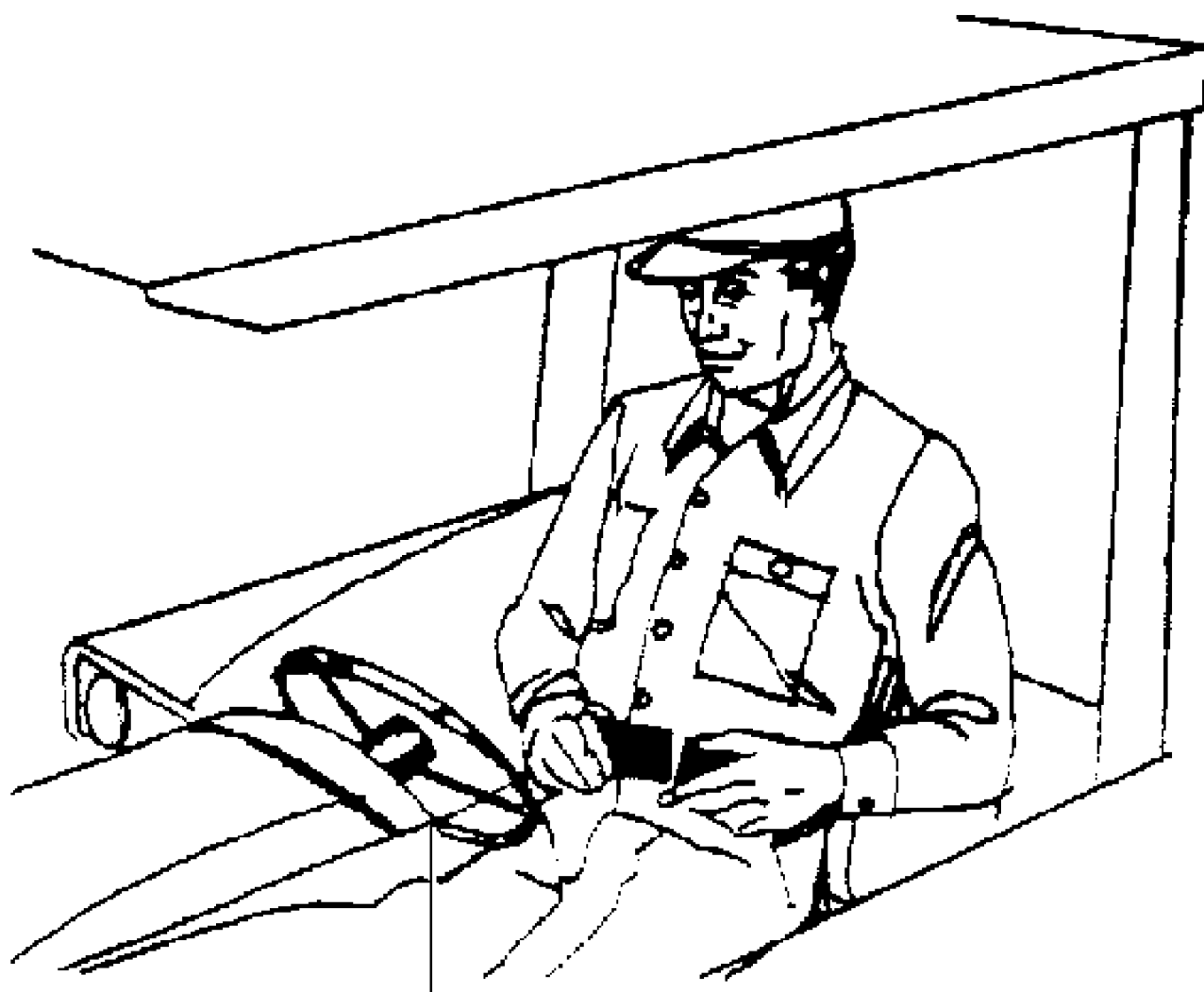

**Buckle up if your tractor is equipped with ROPS.**