



# Tractor Operation Safety<sup>1</sup>

---

New York Center for Agricultural Medicine and Health<sup>2</sup>

## OBJECTIVES

1. Listeners will know where to look for safety rules and information about proper use and operation of tractors.
2. Listeners will be able to list several steps they should take before operating a piece of equipment.
3. Listeners will learn several warning signs that could mean trouble while they are operating a tractor.
4. Students will start to develop a feeling for reactions they should have to stay safe when dangerous situations develop.

## BACKGROUND

Over half of all farm fatalities are a result of a tractor mishap, rollovers being the most common. Run-overs are also common, with PTO entanglements happening all too often as well. Many of these accidents could be avoided if the operator had handled the situation differently. Often lack of understanding the machine, its capabilities and limitations, and proper ways to react to the warning signals it sends out result in a tragic accident. Knowledge of some general safety procedures and the importance of learning specific safety information about each piece of machinery used could save many lives and much pain and expense.

## MATERIALS

A tractor (if possible)

Copies of several tractor owners' manuals

EMI (Equipment Manufacturers Institute) or other general tractor operation safety manual.

Transparencies:

- A. "Know the Rules"
- B. "Check the Equipment"
- C. "For Safe Operation"
- D. Pictures of tractors with mounted equipment

Hand-outs made from the transparencies

## METHODOLOGY

Compare two or more machines from the same category or that appear approximately the same, and show how they have distinct differences in capacity and limitations and handling although there are similarities. Examples might be tractors that have been modified with other equipment such as tracks, mounted corn harvesters, combines with the grain tank full and empty, etc. Discuss the differences such equipment could make in the operation of the machine.

---

1. This training curriculum was produced by the New York Center for Agricultural Medicine and Health (NYCAMH).  
2. New York Center for Agricultural Medicine and Health, One Atwell Road, Cooperstown, New York 13326. Phone number: (607) 547-6023 or 1-800-343-7527 in the Northeast.

Draw on the listeners' experience to make a list of warning signs sent out by a tractor or other self-propelled machine that an operator should be aware of and must react properly to. Appropriate answers might include such things as the front tires bobbing off the ground under certain load conditions, front tires sliding sideways in an attempted turn, the uphill rear tire spinning under a light load, engine stalling from a high speed, or the presence of moving parts near you when you dismount the machine.

Use transparency A to teach basic rules for preparing the operator and the machine for use. Transparency B lists items on the equipment that need to be checked before use for safe operation. Transparency C gives some important rules for safe tractor operation that everyone should know and heed.

It is important to note that this information should not be considered a replacement for the machine's owner's manual, but rather a supplement to it. As mentioned earlier, the differences in each piece of equipment are important and the operator should familiarize himself with each before use.

## EVALUATION

Check for understanding.

1. Have the listeners make a list of items that should be checked on a tractor before it is started.
2. Ask each student to state a safety rule that should be observed while operating a tractor.
3. Give a typical scenario of a dangerous situation developing and ask listeners to comment about actions that should be taken by the operator. Ask what might happen if proper action isn't taken, or if it is taken too late.
4. Students should be able to make a list of general safety rules that apply to the operation of any self-propelled equipment.
5. Provide the listeners with examples of machines that have been modified or have attachments. Ask how the extra weight or modification might change the machine's response to the controls.

## EXTENSIONS

1. Organize owners manuals where they are readily available for review. Provide each machine on your farm with a weather-proof container to keep the owners manual with the machine.
2. Talk with farmers that have survived accidents to find out the causes, the warnings that preceded it, how they reacted and what might have been a better response.
3. If appropriate, look into more in-depth tractor safety and equipment safety classes and courses.

## REFERENCES

*Fundamentals of Machine Operation*  
Deere & Co.  
Moline, IL

*Agricultural Tractor Safety Manual*  
Equipment Manufacturers Institute  
10 S. Riverside Plaza, Chicago, IL

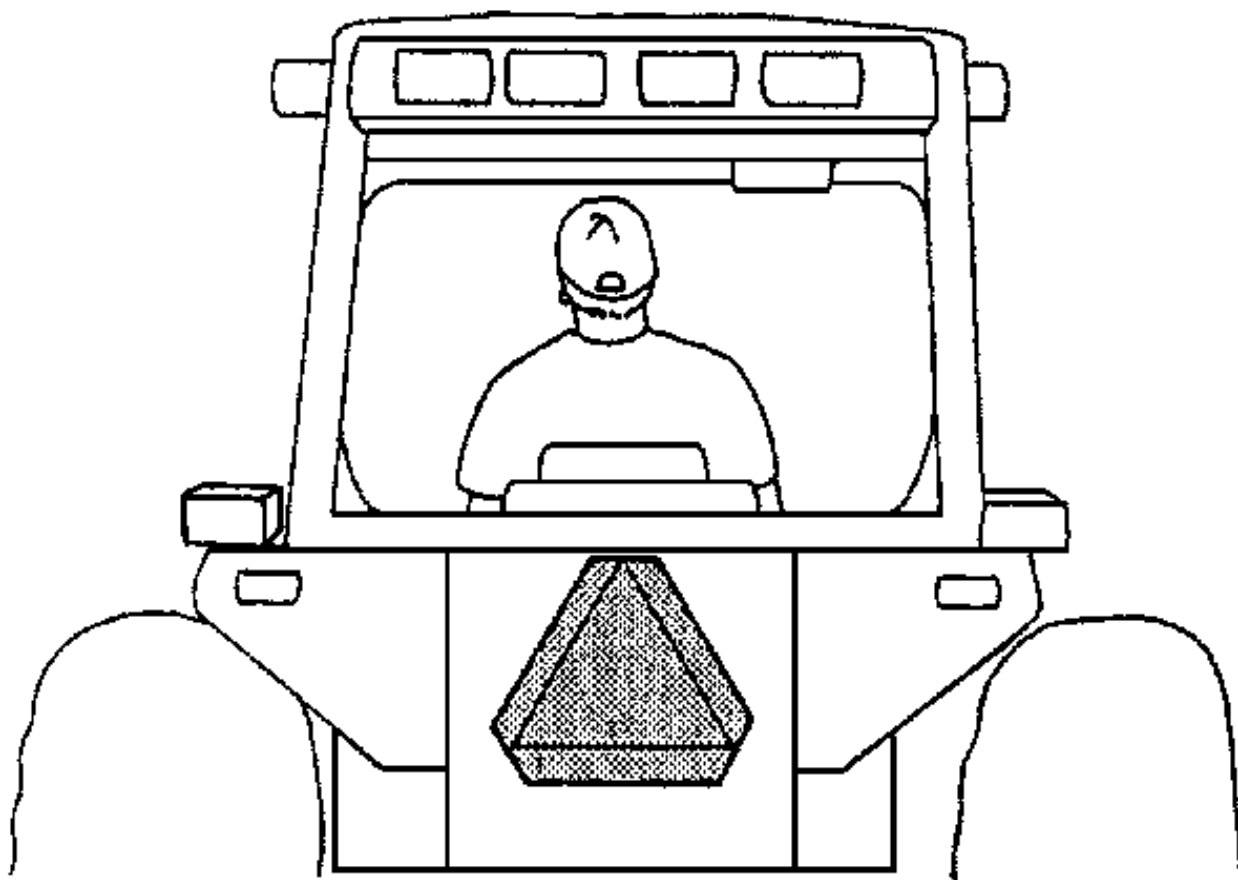

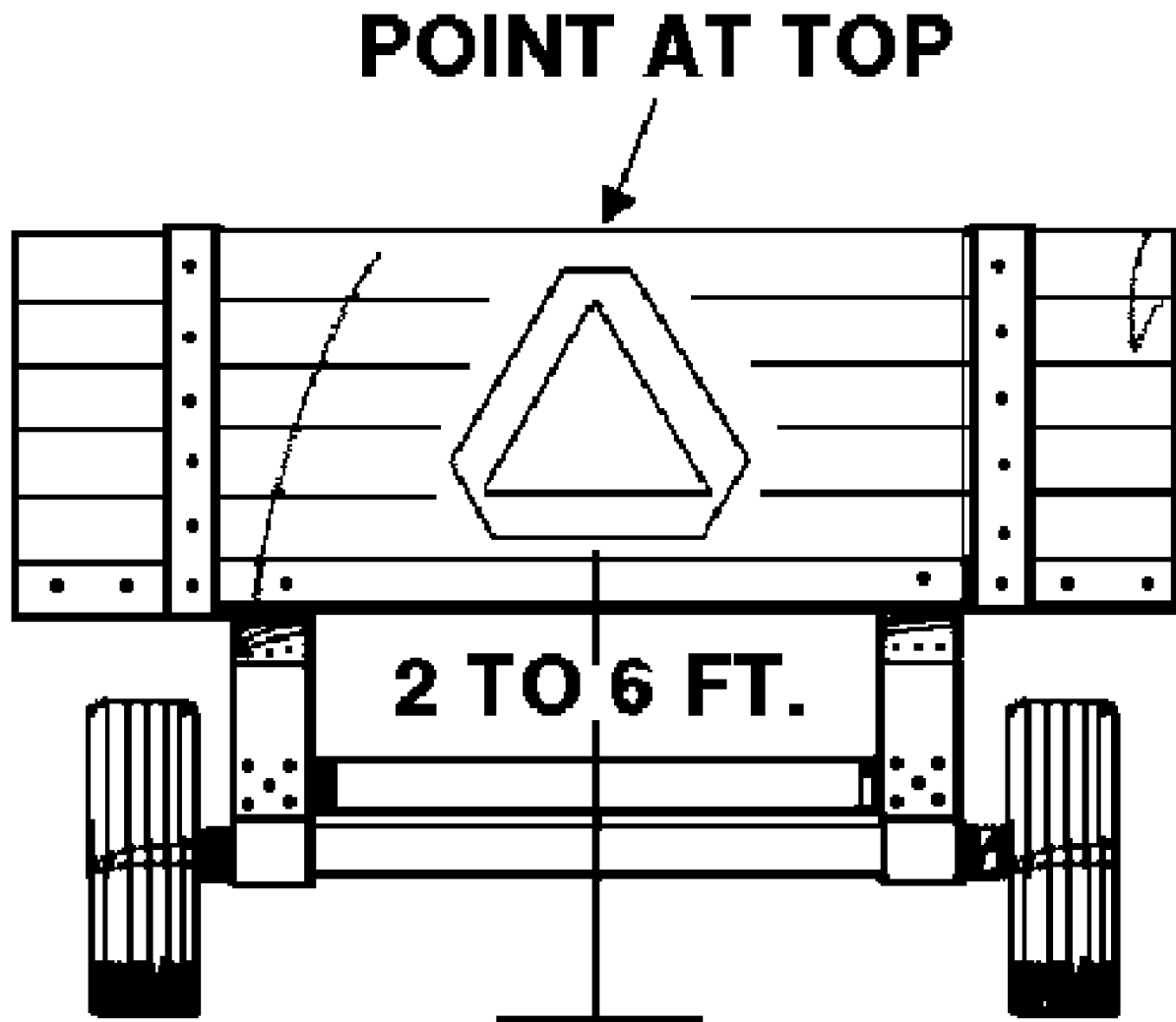

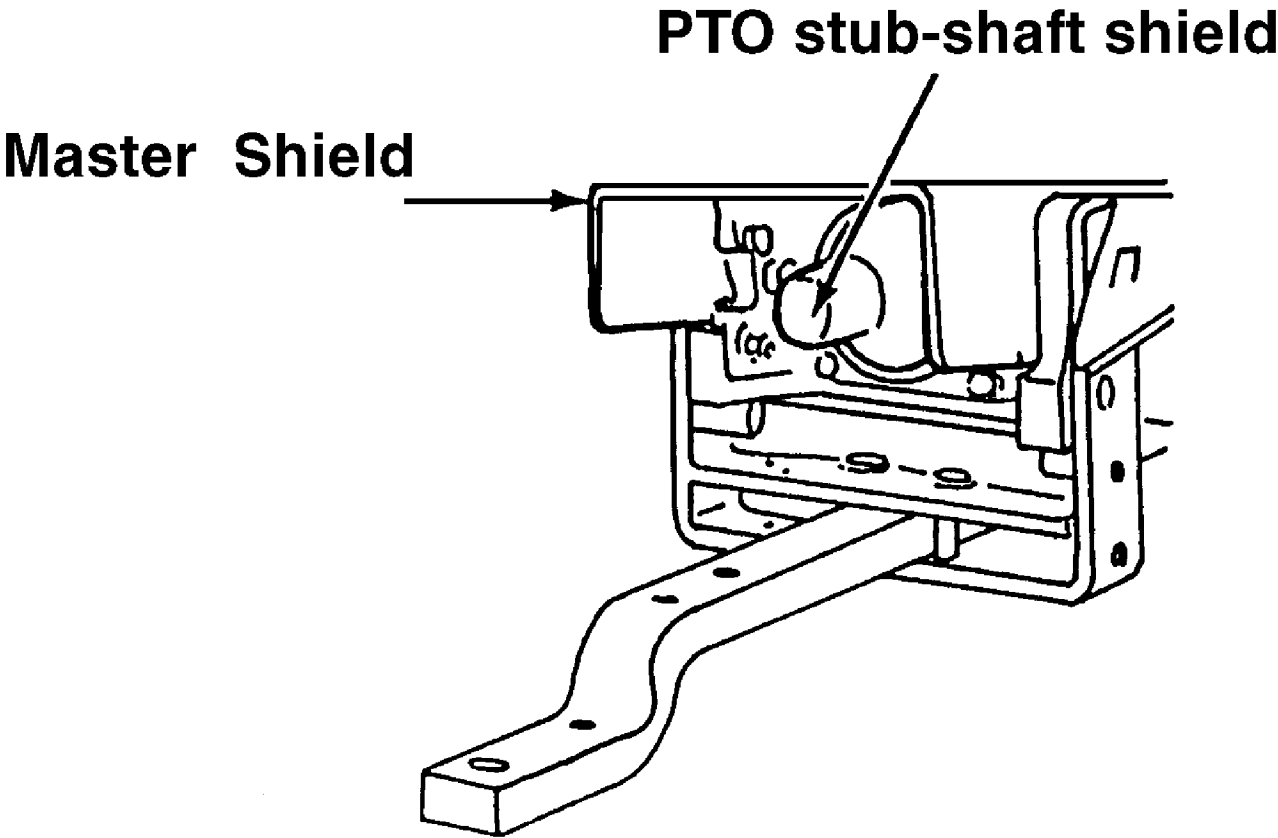

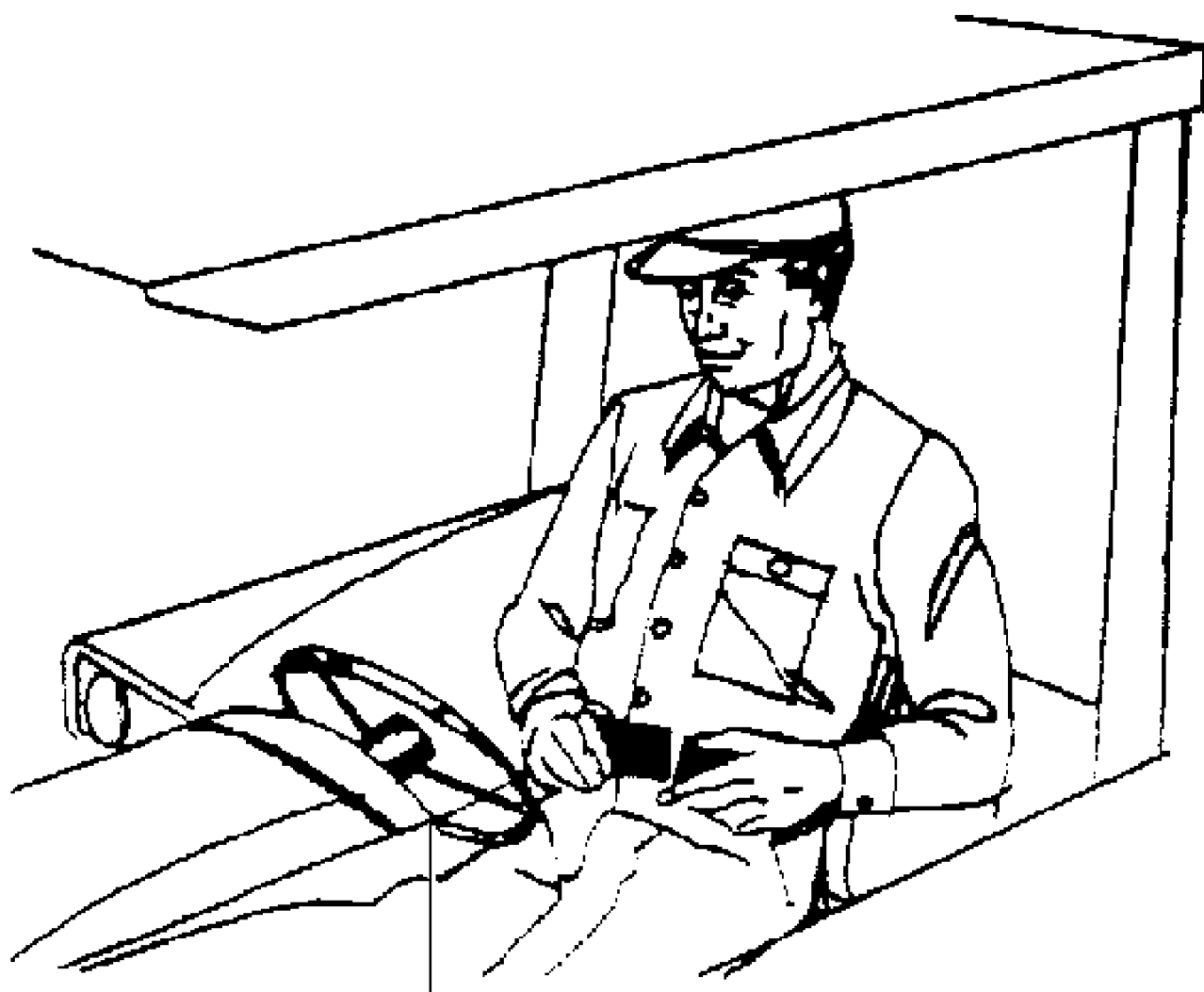

**Buckle up if your tractor is equipped with ROPS.**

# Know the Rules

---

Most farm operations have rules governing operation and maintenance of equipment. Before you start work, check with your supervisor. Ask about rules you may be expected to obey.

These are some rules you must live by:

- Know the capacity and operating characteristics of your tractor and the various attachments and implements you will be using.
- Never modify or remove any part of the equipment.
- Buckle-up your safety belt (if equipped with a roll over protective structure -- ROPS) before you start up. If your tractor is equipped with a foldable/telescopic ROPS follow manufacturer's specific instructions for safety belt use with foldable/telescopic ROPS.
- Keep others away from your operation and remember, **NO RIDERS!**
- Never use attachments unless they are properly matched to your tractor.
- Never allow children or unqualified persons to operate your tractor.
- Before dismounting, always disengage the power take-off (PTO), lower all attachments and implements to the ground, place tractor in park (or neutral), engage parking brake and shut-off the engine.
- If machine is to be unattended, cycle hydraulic controls, and remove ignition key.

**Know the rules -- live by them.**

# Check the Equipment

---

Before you begin your workday, take time to check your machine and have all systems in good operational condition.

- Check for loose, broken, missing, or damaged parts. Have everything put in good repair.
- Make certain all safety devices are in place.
- Check ROPS and safety belt for damage. (A damaged ROPS or safety belt **MUST** be replaced).
- Make certain implements and attachments are properly installed and that the tractor and implement PTO RPM ratings match.
- Check the tires for cuts, bulges and correct pressure. Replace worn or damaged tires.
- Check service and parking brakes for proper operation.
- Check the engine oil system. Add oil if required.
- Perform all maintenance procedures outlined by the tractor manufacturer.
- Check that PTO drive locking devices are latched.
- Check that the tractor PTO shield and driveline guarding are in place and operating properly.
- Check the tractor and implement hydraulic system. Have any leaks or damaged parts repainted.



# For Safe Operation

---

- (1) Securely fasten your seat belt if the tractor has a ROPS (roll over protective structure);
- (2) Where possible, avoid operating the tractor near ditches, embankments, and holes;
- (3) Reduce speed when turning, crossing slopes, and on rough, slick, or muddy surfaces;
- (4) Stay off slopes too steep for safe operation;
- (5) Watch where you are going, especially at row ends, on roads, and around trees;
- (6) Do not permit others to ride;
- (7) Operate the tractor smoothly -- no jerky turns, starts, or stops;
- (8) Hitch only to the drawbar and hitch points recommended by tractor manufacturers;
- (9) When tractor is stopped, set brakes securely and use park lock if available.



**WARNING:** An operator should not use alcohol or drugs which can change his alertness or coordination. An operator on prescription or over-the-counter drugs needs medical advice on whether or not he or she can safely operate machines.