

Preventing Farm Machine Hazards¹

Thomas L. Bean²

Each year, 2,600 farm residents are killed and 230,000 disabled in farm-related injuries, many due to farm machinery. Farm machinery uses mechanical power to do work. This creates a number of possible hazards for both operators and bystanders. Even though manufacturers take many steps to make machinery safe, all hazards cannot be removed. Some machine parts cannot be completely shielded and still do their job. For instance, a totally enclosed cutting blade could not cut.

Many machinery-related accidents result from human error. The operator either forgot something, took a shortcut or a risk, ignored a warning, wasn't paying close attention, or failed to follow safety rules. In addition, guards removed for maintenance often aren't replaced.

There are many different kinds of farm machinery: mowers, tractors, shredders, harvesters, grinders, blowers, augers, balers, etc. They all have similar characteristics and hazards. You can be cut, crushed, pulled in or struck by an object thrown by these machines. They have cutting edges, gears, chains, revolving shafts, rotating blades, pinch points and other hazards. You can also be injured if you fall while working on or near any of these machines.

Accidents with farm machinery are often serious, even fatal. It is important to recognize and be alert for machine hazards and to take precautions to avoid injury.

SHEAR AND CUTTING POINTS

Shear points (Figure 1) are created when the edges of two objects are moved together closely enough to cut a soft material, as with a pair of shears or an auger. Cutting points are created when a single object moves forcefully or rapidly enough to cut, as with a rotary mower blade.

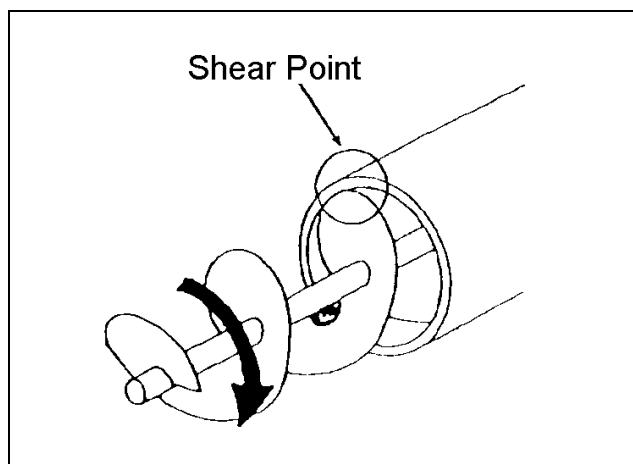

Figure 1. Example of a shear point

Both shear and cutting points are created on machinery designed to cut, such as harvesters, and on those that are not designed to cut, such as augers. They are hazardous because of their cutting force and they often move so rapidly that they may not be visible, so it is easy to forget they are operating or to underestimate the hazard.

1. This document is AEX-593, a series of the Agricultural Engineering Department, Ohio State University Extension, Columbus, Ohio 43210. Funded in whole or in part from Grant #U05/CCU506070-01, "Cooperative Agreement Program for Agricultural Health Promotion Systems," National Institute for Occupational Safety and Health. Publication date: December 1991.
2. Thomas L. Bean, Safety Leader, Ohio State University Extension, Columbus, Ohio 43210. Reviewed by Dr. Randall Wood and Dr. Warren Roller.

Issued in furtherance of Cooperative Extension work, Acts of May 8 and June 30, 1914, in cooperation with the U.S. Department of Agriculture, Bobby D. Moser, Director of the Ohio Cooperative Extension Service, The Ohio State University. All educational programs and activities conducted by the Ohio Cooperative Extension Service are available to all potential clientele on a non-discriminatory basis without regard to race, color, creed, religion, sexual orientation, national origin, sex, age, handicap or Vietnam-era veteran status.

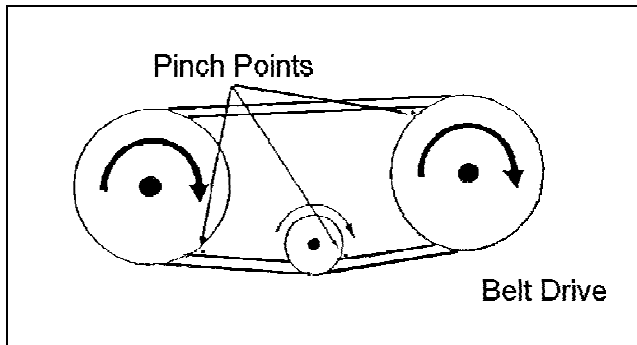

Figure 2. Examples of pinch points

Because some shear and cutting points cannot be guarded, it is important to be aware of their hazard and stay alert when they are operating. It is also important to warn others and to look out for their safety. This is especially true if there is a danger of thrown objects while using cutting-type equipment.

PINCH POINTS

Pinch points are another hazard of farm machinery (Figure 2). Pinch points (which should be more appropriately named mangled or maimed points) are formed when two rotating objects move together and at least one of them moves in a circle. For example, the point at which a belt runs into a pulley is a pinch point. Belt drives, chain drives, and gear drives are other sources of pinch points in power transmission devices. Feed rolls, gathering chains and similar equipment designed to draw crops into the machine also create pinch points.

Fingers, hands and feet can be caught directly in pinch points, or they may be drawn into the pinch points by the inertia of the moving part or loose clothing that becomes entangled. Contact may be made by falling or brushing against unshielded parts. You can become entangled in pinch points if you take chances and reach or work near rotating parts. Machines move too fast to get out of a pinch point once you become caught.

To avoid injury from pinch points, be aware where pinch points occur and avoid them. Wear clothing that fits well and is not loose or floppy. Never reach over or work near rotating parts. Turn off machinery to work on it. Always replace shields removed for maintenance.

WRAP POINTS

Rotating shafts are the most common source of wrap-point accidents, although any exposed machine part that rotates can be a wrap point. A cuff, sleeve, pant leg, long hair or just a thread can catch a rotating part and result in serious injury. Entanglement with a wrap point can pull you into the machine, or clothing may become so tightly wrapped that you are crushed or suffocated. In other cases, you could be thrown off balance and fall into other machinery parts.

Even a perfectly round shaft can be hazardous if there is enough pressure to hold clothing against the shaft. Hazards increase with shafts that are not round. Clothing is more likely to catch if there is dried mud or manure on the shaft, or if the shaft is nicked. Ends of shafts that protrude beyond bearings are also dangerous. Universal joints, keys and fastening devices can also snag clothing.

Check all equipment for potential wrap points and, if possible, shield those that can be shielded. Replace any damaged manufacturer-installed warning labels and place warnings on equipment parts not previously labeled. In addition, consider painting them a bright color, perhaps with wide stripes. Be aware of wrap points and be alert to their danger.

CRUSH POINTS

Crush points are created when two objects move toward each other or one object moves toward a stationary object. For example, hitching tractors to implements (Figure 3) creates a potential crush point.

Hitch accidents most commonly occur to fingers placed at the hitching point. Wait until the tractor has stopped before stepping into the hitching position. If possible, arrange the hitch point so that the tractor can be backed into position without anyone between. Always know what the other person is doing.

Failure to safely block up equipment can result in a fatal crushing injury. A jack may slip, a hose or overhead support may break, or the equipment may roll. Take extra precautions when working with machinery that is raised for any reason.

The operator's head or chest can be crushed between the equipment and a low beam or other part of a farm building. These accidents usually occur when the machine is being operated in reverse. Tree limbs are also potential hazards when working with tractors and other

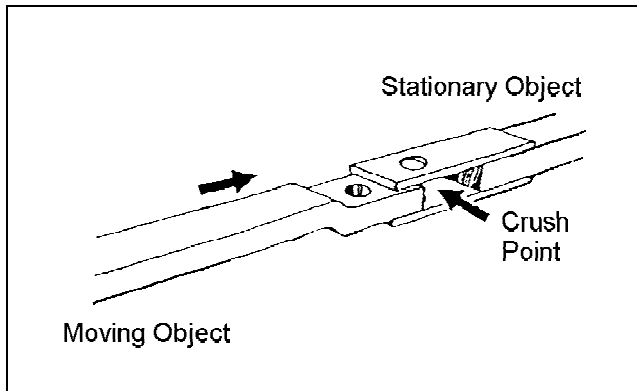

Figure 3. Example of a crush point

machinery.

To prevent being crushed or pinned, recognize and avoid potentially dangerous situations. Block all machinery securely if you must work under it. If an implement can roll freely, block its wheels so it cannot roll.

FREE-WHEELING PARTS

Many machine parts continue to spin after the power is shut off, including cutter heads of forage harvesters, hammer mills of feed grinders, rotary mower blades, fans and flywheels. Never touch these parts until they have stopped moving. This could take 2 to 2½ minutes.

SPRINGS

Compressed springs (Figure 4) will expand with great force when released, and springs that are stretched will contract rapidly when released. Know what direction a spring will move and how it might affect another machine part when released, and stay out of its path.

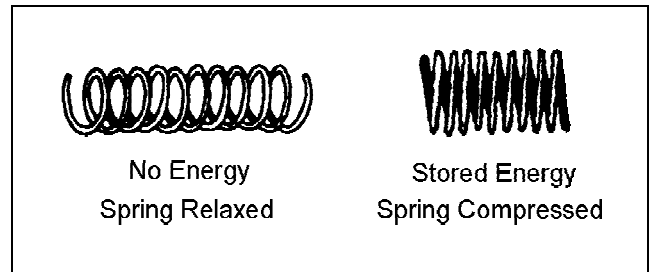

Figure 4. Examples of spring energy

BURN POINTS

Be aware of burn points: mufflers, manifolds and even gear cases under adverse climatic conditions. They may not be severe enough to seriously maim, but they can startle the operator enough to cause him or her to jump into more deadly danger.

HYDRAULIC SYSTEMS

Hydraulic systems contain fluid under extreme pressure. Before loosening, tightening, removing or otherwise working with any fittings or parts, relieve this pressure. Jet streams from even pinhole leaks can penetrate flesh. In addition, the liquid is often hot. Before attempting any service on hydraulic systems, shut off the engine that powers the hydraulic pump. Lower the implement to the ground and relieve the pressure. Follow instructions in the operators manual because the specific procedures for servicing the systems are very important to your safety.