

Machinery Safety on the Farm

Robert "Bobby" Grisso, Bruce Stone, and Glen Hetzel*

Machines; no farm or ranch can function without them. They save valuable time and are essential to agricultural productivity. They also represent an ever-present danger to the people who operate them. There are a host of hazards that makes agricultural machinery the leading cause of injury and death on American farms and ranches.

This fact sheet summarizes the hazards associated with operating farm machines and presents information about how farmers and farm workers can protect themselves from injury or death when working around agricultural machinery.

Safe machinery operation primarily depends on how you operate the machine. Machines are inanimate objects; they cannot think, reason, or adapt to meet the needs of people. The responsibility for machinery safety rests with you. Just as we are told to drive defensively when operating an automobile, machine operators should always be thinking ahead and anticipating potential hazards.

Common Machinery Hazards

Machines are designed to use power, torque, motion, and energy to perform work. They may be powered by power takeoff drivelines, hydraulic oil pressure, electrical motors, internal combustion engines, or ground traction. Regardless of how machines are powered, they present a number of hazards to those working around them.

There are several dangerous areas that can cause injury, dismemberment, and/or the death of the operator. Below are machinery related hazard areas.

- **Pinch points** are areas where two or more parts move together with at least one part moving in a circle. The

areas where drive belts contact pulleys or sprockets mesh with chains are prime examples of pinch points (Figure 1).

- **Crush points** are hazards involving two components moving toward each other (Figure 2). Examples of crush-point hazards are the raising and lowering equipment with a three-point hitch, components that

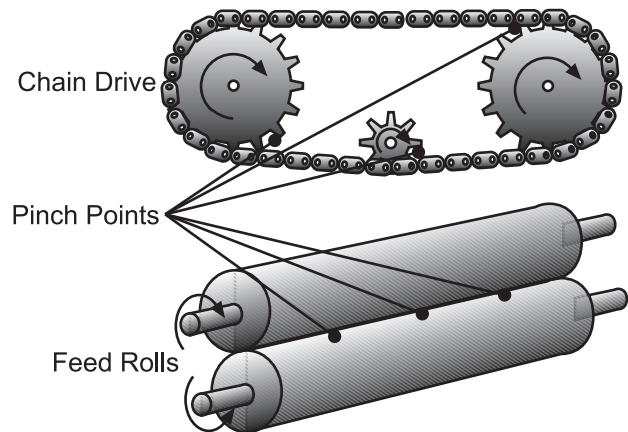

Figure 1. Pinch points on rotating parts can catch clothing, hands, arms and feet.

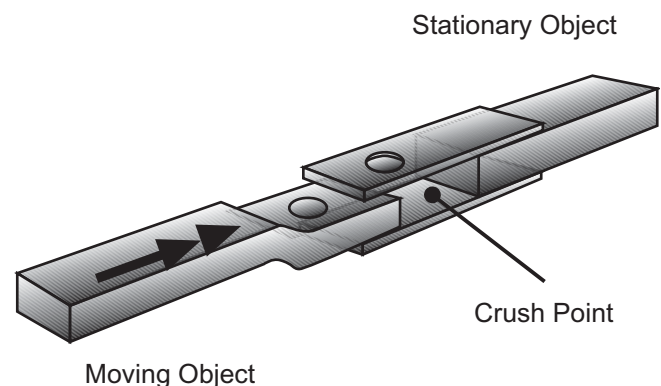

Figure 2. Hitches present typical crush points.

*Extension Engineer, Biological Systems Engineering, Virginia Tech; Safety Manager, Virginia Farm Bureau Insurance Services, Richmond; Retired Farm Safety Specialist, Biological Systems Engineering, Virginia Tech; respectively

are moved by hydraulic cylinders, and the areas between the tractor and machinery when hitching or turning.

- **Wrap (entanglement) point** hazards pertain to any exposed rotating component. Wrap-point hazards include any type of rotating shaft or driveline. PTO drivelines are prime examples of wrapping or entanglement hazards (Figure 3).
- **Pull-in point** hazards involve mechanisms designed to take in crops or other materials for processing. They include combine headers, windrow pickups, forage chopper headers, and grinders (Figure 4).
- **Shear and cutting point** hazards are areas where two parts move across one another or one moves across a stationary object. Windrower cutter bars and grain augers are examples of cutting and shear points.
- **Thrown objects** present another type of machine hazard. Metal, glass, wire, sticks, or other materials may be picked up by a machine and propelled with extreme force. Rotary mowers are good examples of machines capable of throwing objects.
- **Burn point** hazards are associated with tractors and self-propelled and pull-type machinery. Hot mufflers,

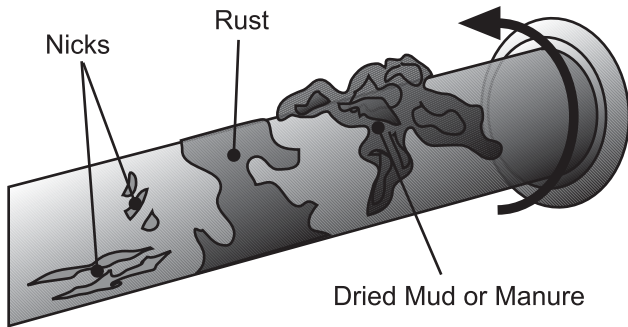

Figure 3. These conditions can cause clothing to wrap around a PTO driveline.

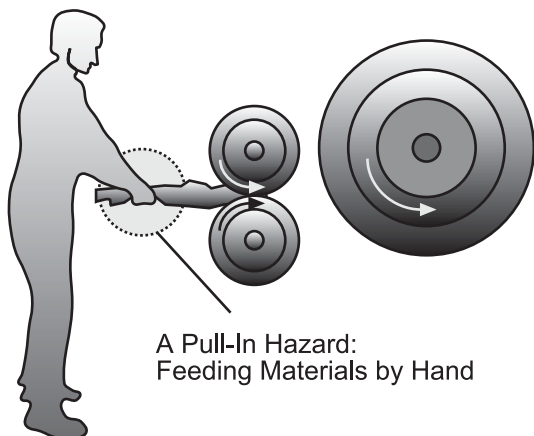

Figure 4. Machinery can pull you in faster than you can think to let go.

engine blocks, pipes, and hot fluids are examples of burn points.

- **Stored energy** hazards are present in pressurized systems such as hydraulics, compressed air, and springs. The sudden or unsuspected pressurization or depressurization of these systems can result in crushing and other types of accidents, depending on the use of the system. High-pressure leaks are also forms of stored energy hazards.

Become a Safe Machinery Operator

Safe machinery operators respect machines for the work they perform and the dangers they present. In order to become a safe machinery operator:

- Learn to operate your machinery properly. Use the operator's manual as a guide.
- Learn the hazards involved with machinery operation; be proactive and anticipate dangerous situations.
- **Be alert** at all times when operating machinery. Take breaks and get sufficient food and rest to stay alert.
- Always follow recommended safe practices for operating machinery.

Safety Guards and Warning Signs

Modern farm machinery is factory equipped with a variety of safety features, including guards, shields, and warning signs designed to reduce injuries. Needless injuries and deaths occur because safety guards are removed, broken, or torn off during operation. Take the time to inspect your machinery for missing or damaged safety guards and signs. If guards or signs are missing or damaged, repair or replace them before using the machine. **Never operate a machine with missing guards.**

Repairs and Adjustments

Repairs and adjustments are frequently necessary to ensure optimum machinery performance and efficiency. Numerous accidents occur because operators attempt to make repairs or adjustments while a machine was running. Others have been injured or killed by being crushed when equipment fell while they were working underneath it. **Protect yourself.** Before making any repair or adjustment, no matter how minor, be sure to turn off the machine, turn off the tractor, and take the key. Do not depend on the hydraulic system to keep the implement or attachments in the raised position; prevent them from falling by placing

blocks beneath them. Only then can needed adjustments or repairs be made safely.

Power Take off (PTO) Drivelines

Power takeoff drivelines (shafts) are among the oldest and most common machinery hazards (Figure 5). Exposed bolts, universal joints, burrs, or other projections on rotating components can grab clothing, resulting in instant entanglement. Do your part to reduce PTO injuries and deaths:

- Ensure PTO drivelines are fully shielded (Figure 6).
- Never attempt to step over rotating PTO drivelines, no matter how slowly they may be turning.
- Never attempt to operate tractor controls from the rear of the tractor.
- Never wear loose, baggy clothing around PTO drivelines.
- Keep long hair pulled back to avoid entanglement.
- Stay well clear of rotating PTO drivelines.

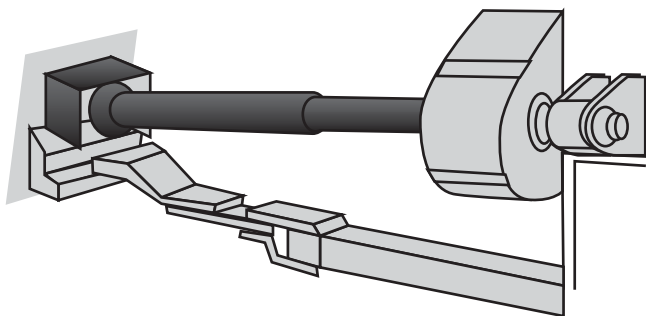

Figure 6. Shielded for safety: keep dangerous rotating parts covered on PTO driveline.

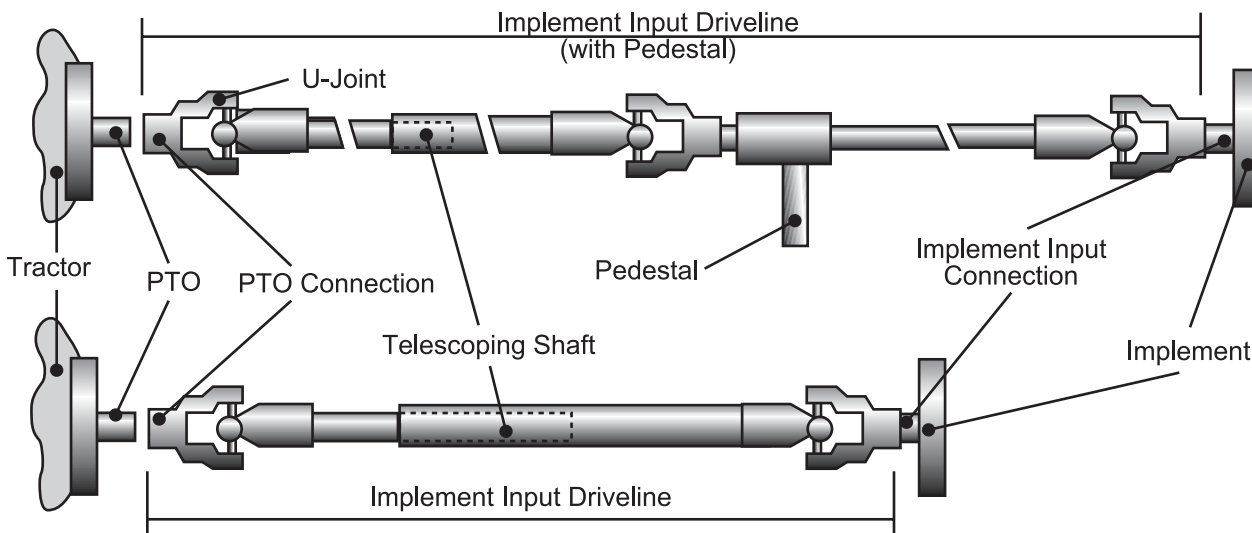

Figure 5. Major components of a PTO driveline.

Plugged Machinery

Combines, hay balers, and other harvesting machines are prone to plug-ups. Normally, these plug-ups occur at the point where material enters the machine and must be removed before harvesting can continue. Attempting to unplug materials from a running machine can easily result in death or dismemberment by being pulled into the machine. Remember, you cannot win a strength or speed contest with these machines. You can't let go of the material quickly enough to keep from being pulled into the machine. If a machine is plugged, the mechanical components may be under pressure even when the power is turned off. When the plug is removed the components may begin to move. **Make it your rule to turn off the machine and its power source before attempting to clear any plugged machine.**

Protecting Others from Danger

You can be instrumental in protecting others from danger. Do your part to protect others from needless injuries while operating agricultural machinery by:

- Training your employees and family members to operate machinery in the correct manner.
- Teaching family members and employees about the hazards involved with agricultural machinery.
- Keeping children away from agricultural machinery, whether it is running or idle.

References:

Safety and Health for Production Agriculture. 1992. ASAE Textbook Number 5, American Society of Agricultural Engineers, St. Joseph, Mo. <http://www.asae.org/pubs/textmono.html>

Fundamentals of Machine Operation - Agricultural Safety. 1987. Deere and Company, Moline, Ill.

Acknowledgement:

This information was adapted from an Extension fact sheet (F-1727) entitled *Machinery Safety on the Farm* by M. Stapper and J. Oskan of the Oklahoma State University Extension Service, Stillwater, Okla.

The authors would like to express their appreciation for the review and comments made by Glenn Chappell, Extension agent, Prince George County; Samuel M. Johnson, Extension agent, Westmoreland County; Tom Stanley, Extension agent, Augusta County; Robert Pitman, superintendent, Eastern Virginia Agricultural Research and Extension Center; David Holshouser, associate professor and Extension soybean specialist, Tidewater Agricultural Research and Extension Center; and David Vaughan, professor, Department of Biological Systems Engineering; all from Virginia Tech.